

Photo Kiosk P510K Service Guide



Version: 1.5

Outlines:

CHAPTER 1: INTRODUCTION	4
CHAPTER 2: SPECIFICATIONS.....	5
2-1. ACCESSORIES	6
2-2. OPERATING CONDITION	6
CHAPTER 3: OPERATION THEORY	8
3-1. HARDWARE – IPC	9
3-2. HARDWARE – PRINTER.....	13
3-3. PRINTER OPERATION CHART.....	21
3-4. MECHANISM & MOVEMENTS.....	22
CHAPTER 4: DISASSEMBLY & ASSEMBLY	27
4-1 TOOLS REQUIRED.....	27
4-2 PROHIBITION.....	27
4-3 PRECAUTION	28
4-4 PARTS REPLACEMENT PROCEDURE.....	29
4-4-1 MAIN COVER REMOVAL PROCEDURE.....	29
4-4-2 P510K PHOTO PRINTER KIOSK M/B	35
4-4-3 POWER BD P510K TO KIOSK SYSTEM	36
4-4-4 FRAME_MID_P510K	37
4-4-5 MAIN_BD P510K 011 ROHS.....	38
4-4-6 POWER BD P510 002 ROHS.....	39
4-4-7 PCB TPH_BD P510 041 ROHS.....	40
4-4-8 MTR STEP_7.5_6OHM_RBN_S_160MM ROHS.....	41
4-4-9 MTR STEP_7.5_6OHM_CAM_PLTN_200MM RED ROHS	42
4-4-10 MTR STEP_7.5_4OHM_CAM_PINCH_90MM ROHS.....	43
4-4-11 MTR STEP_7.5_6OHM_RBN_T_350MM ROHS.....	44
4-4-12 MTR STEP_1.8_2.4V_2.5A CAPSTON_250MM ROHS	45
4-4-13 MTR STEP_3.75_8.5OHM_PAPER_EXIT 240MM BLUE ROHS.....	46
4-4-14 FRMAE_MAIN_P510K.....	47
4-4-15 ROLLER_EXIT_PINCH_CUTTER_A5.....	48
4-4-17 LINKAGE_MODULE_P510S.....	52
4-4-18 TRAY_EXIT_ASSY.....	55
4-4-19 SUB_TPH_ASSY	57
4-4-20 CAPSTAN_ROLLER_A5.....	59
4-4-21 ROLLER_PLATEN_NEW_A5.....	61
4-4-22 ROLLER_PINCH_A5.....	63
4-4-23 TRAY_FEED.....	65
4-4-24 WIRE DOOR_SNR 310MM ROHS.....	66
4-4-25 WIRE PAPER_BOX_SNR 390MM BLUE ROHS	67
4-4-26 WIRE PAPER_TYPE 590MM ROHS.....	69
4-4-27 WIRE PAPER_OUT 680MM ROHS.....	70
4-4-28 WIRE LE_FEED_SNR 490MM ROHS.....	71
4-4-29 WIRE JAM_SNR 340MM ROHS,WIRE JAM_LED_290MM ROHS.....	72
4-4-30 WIRE RBN_SNR_LEFT 120MM ROHS,WIRE RBN_SNR_RIGHT 160MM ROHS,WIRE RBN_LED_LEFT 350MM ROHS,WIRE RBN_LED_RIGHT 470MM ROHS.....	73
4-4-31 WIRE CAM_PINCH 180MM ROHS	75
4-4-32 WIRE SMART_CHIP 240MM ROHS.....	76
CHAPTER 5: MAINTENANCE.....	77
CHAPTER 6: ADJUSTMENT	79
CHAPTER 7: GEAR LIST.....	84
CHAPTER 8: ERROR MESSAGE	86
CHAPTER 9: CONTACT INFORMATION	91

Chapter 1: Introduction

This document contains operation theory and parts replacement procedures that are intended to ease the task of transportation, usage, maintenance and parts replacement.



The P510K is a new generation printer that is designed for fast and massive printing solution. As compare to other series, Research & Development Team has reduced many adjustment and alignment of mechanism and hardware of this printer to reduce the time and effort in servicing.

Chapter 2: Specifications

Item	Description
Printer Method	Dye-Diffusion Thermal Transfer (D2T2 Technology)
Resolution	300 x 300 dpi
Colors	Approx. 16.7M colors (YMCO, 256 level for each color, continuous tone)
Thermal Print Head	- Heat Element: Thin-film resister - Numbers of Element: 1,844 - Element Layout: On horizontal row arranged - Element Density: 300 dpi
Dot Pitch	- Horizontal dot pitch 0.0845 mm (300-dot lines per inch) - Vertical do pitch 0.0845 mm (300-dot lines per inch)
Noise Level	Operation: 65 db or less
Printing Speed (6x4)	Print time <13 sec for 6x4; <20 for 5x7 photo printing; <23 sec for 6x9 photo printing; Print time refers to Y-layer to O-layer printing
Printing Size & Capacity	4"x6" (102 x 152 mm): 330 prints
	5"x7" (127 x 177 mm): 190 prints
	6"x8" (152 x 204 mm): 150 prints
	6"x9" (152 x 229 mm) : 150 prints
User Interface Panel	10.2 inch Liquid Crystal Display with 1024 x 600 resolution 10.2 inch 5-wires touch panel
Media	CF, Micro Drive, SD (SDHC), Mini SD, Micro SD, MMC, MS, MS Pro, USB Pen Drive
Operation System	Linux
Flash Memory	2GB CF Card
Printer Compatible Image File Format	JPEG, TIFF, GIF, BMP
Dimension & Weight	430*305*340 mm (L*W*H), 18.2kg (40lbs)
Consumables (Ink Ribbon and Paper)	<u>6x4 Print Kit</u> <ul style="list-style-type: none"> ● 330 Prints Per Roll, 2 Rolls In a Carton ● 330 Prints Per Roll, 2 Cartridges In a Carton
	<u>5x7 Print Kit</u> <ul style="list-style-type: none"> ● 190 Prints Per Roll, 2 Rolls In a Carton ● 190 Prints Per Cartridge, 2 Cartridges In a Carton ● Paper Size: 127mm x 178mm
	<u>6x9 Print Kit</u> <ul style="list-style-type: none"> ● 150 Prints Per Roll, 2 Rolls In a Carton ● 150 Prints Per Cartridge, 2 Cartridges In a Carton ● Paper Size (6x8): 152mm x 203mm ● Paper Size (6x9): 152mm x 229mm
Power Source (Frequency)	AC 100 – 240 V, automatic switching ; 50 - 60 Hz
AC Rush	30A or less at 120VAC, 60Hz (Except less than 100usec surge)
Power Consumption (maximum value)	Standby 40W @100VAC 0.7Ampere or 220VAC 0.35Ampere Printing 350W @100VAC 4.1Ampere or 220VAC 2.0Ampere
Safety Regulations	UL60950-1 C-UL (Conform to CSA C22.2 No.60950-1) EN60950-1
EMI Regulations	VCCI Class A FCC part15 Class A EN55022 Class A

2-1. Accessories

No.	Item Name	Quantity
1	P510K	1
2	Power Cord	1
3	USB Cable	1
4	Master CD (Driver, e-User Manual, ID Creator)	1
5	P510K User Manual	1
6	Spacer	2
7	Flange	2

2-2. Operating Condition

2-2-1. Temperature & Humidity

	Item	Spec	Remark
Operation	Temperature	+10°C to +35°C	No quality degradation
	Relative Humidity	20% to 80% RH	
Storage	Temperature	-20°C to +55°C	No quality degradation after testing
	Relative Humidity	20% to 90% RH	

2-2-2. Location

Locate the printer in place not exposed to rainwater, direct sunlight, etc.

2-2-3. Dust Prevention

No printer faults will occur under normal condition

2-2-4. Operating environments

The printer is to be used in an ordinary environment unless otherwise specified. Use of the printer in a special environment as shown below shall be discussed separately:

- Environment where the printer is always subjected to oily smoke or exhaust gas
- Chemical atmosphere
- Outdoors

2-3. Print Area

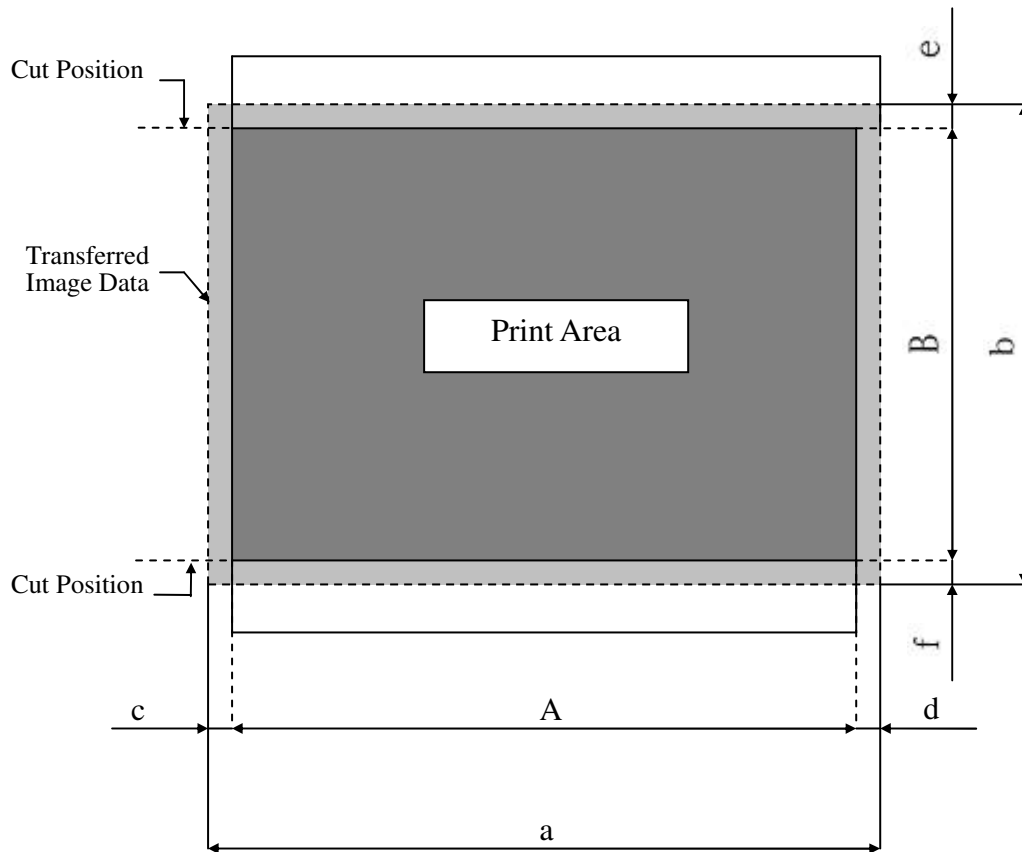

Name	Print Area (Finished Size)		Data Image Area: The value in parentheses is the number of pixels			Area with no prints (Width Direction)		Dummy print area (Feed Direction)	
	A	B	a	b	Image Sized	c	d	e	f
5x3.5 size	127 ^{+/- 0.5} mm	89 ^{+/- 1.0} mm	130.8 mm	92 mm	1544x1088 pixels	1.9 ^{+/- 2.0} mm	1.9 ^{+/- 2.0} mm	1.5 ^{+/- 1.0} mm	1.5 ^{+/- 1.0} mm
6x4 size	152 ^{+/- 0.5} mm	102 ^{+/- 1.0} mm	155.8 mm	105 mm	1844x1240 pixels	1.9 ^{+/- 2.0} mm	1.9 ^{+/- 2.0} mm	1.5 ^{+/- 1.0} mm	1.5 ^{+/- 1.0} mm
5x7 size	127 ^{+/- 0.5} mm	179 ^{+/- 1.0} mm	130.8 mm	182.0 mm	1544x2140 pixels	1.9 ^{+/- 2.0} mm	1.9 ^{+/- 2.0} mm	1.5 ^{+/- 1.0} mm	1.5 ^{+/- 1.0} mm
6x8 size	152 ^{+/- 0.5} mm	204 ^{+/- 1.0} mm	155.8 mm	207.0 mm	1844x2434 pixels	1.9 ^{+/- 2.0} mm	1.9 ^{+/- 2.0} mm	1.5 ^{+/- 1.0} mm	1.5 ^{+/- 1.0} mm
6x9 size	152 ^{+/- 0.5} mm	230 ^{+/- 1.0} mm	155.8 mm	233.0 mm	1844x2740 pixels	1.9 ^{+/- 2.0} mm	1.9 ^{+/- 2.0} mm	1.5 ^{+/- 1.0} mm	1.5 ^{+/- 1.0} mm

Chapter 3: Operation Theory

Circuit Boards Definition:

There are 2 power boards both connected to the power connector, but controlled separately by 2 different main boards. It can be defined as a computer at top and a printer at bottom, integrated together.

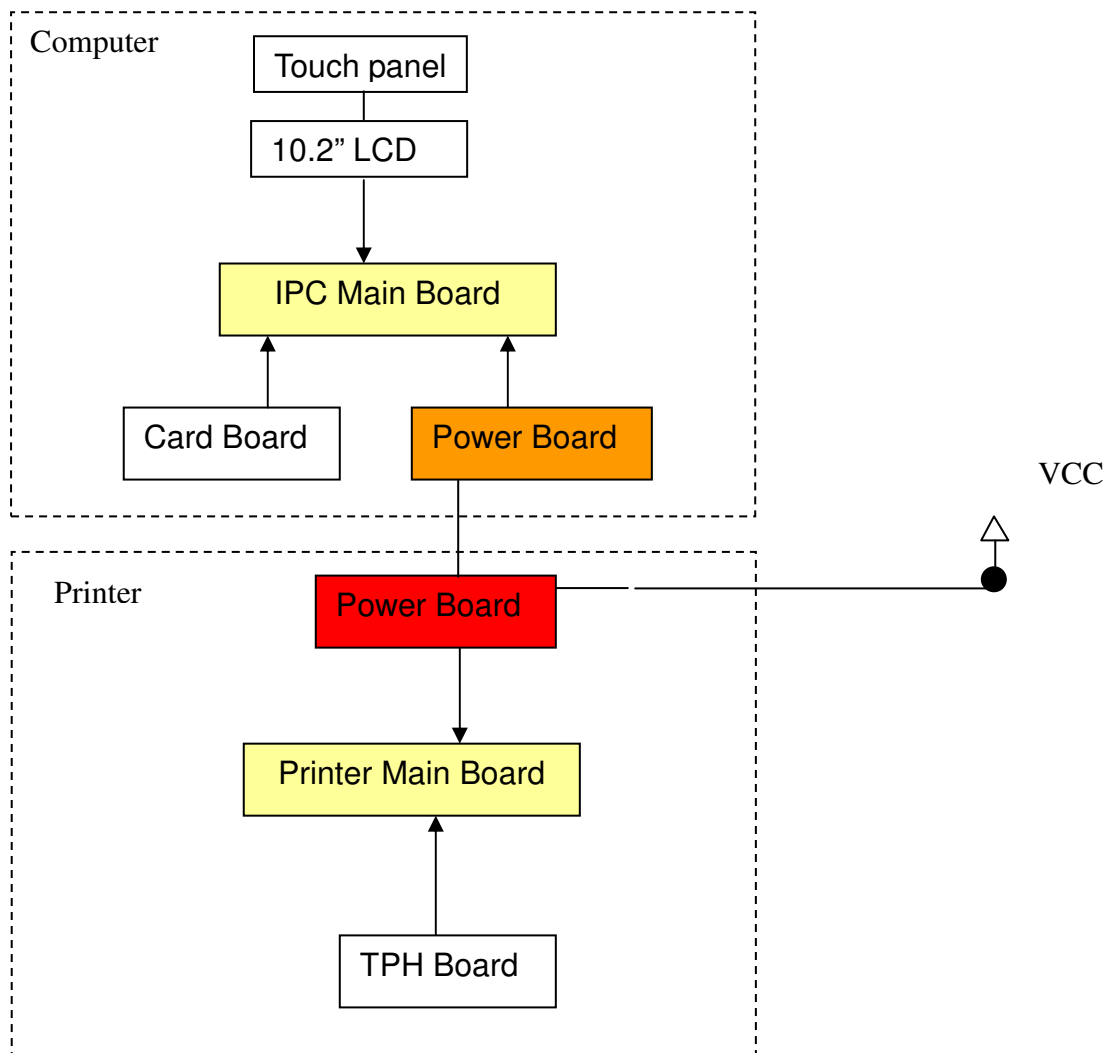

3-1. Hardware – IPC

3-1-1 Main board Spec

Item	Description
CPU	Intel CeleronM 1GHz zero cache processor
Chipset	Intel 852GM + ICH4
System Memory	One 184-pin DDR 266MHz up to 1GB (default: 512 MB)
I/O Interface	- 1 x 100base Ethernet RJ45 connector - 6 x USB 2.0 (5 pin headers, 1 USB A type) - 1 x CF card socket (IDE mode) - 1 x IDE Connector - 3 x RS-232 (1 x pin headers, 2 D-Sub) - 1 x IrDA pin headers - 1 x Mini PCI Expansions slot - 24-bit LVDS Display interface
Power Supply	AT mode power supply support
Dimension	170 x 170mm
Power requirement	5V @ 2.2A 5VSB @ 0.5A 12V @ 0.5A

3-1-2 BIOS

- **BIOS Setup:**

The battery CR-2032 is available for 1527 days since power supply is AT type, not ATX type. Change battery CR-2032 while incorrect date/time information happens every time.

Connect USB keyboard to P510K then click 'DEL' key to get in BIOS SETUP UTILITY when power on.

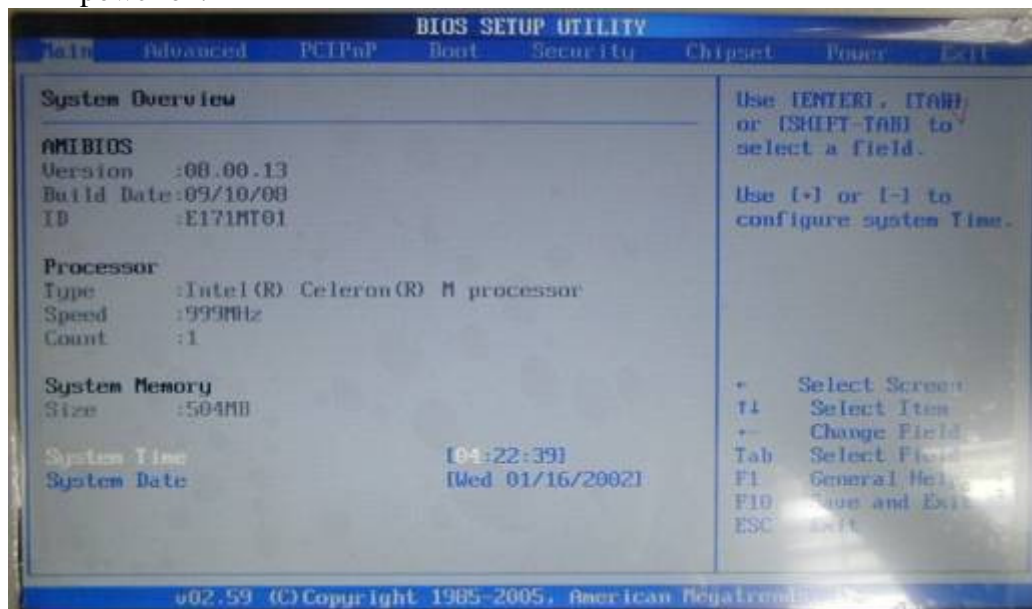

● BIOS Reset:

Move and connect jumper to another pin to reset BIOS (after 5 seconds, put it back to the original position) if no display shows or beep sound occurs after power on the printer.



● BIOS beep codes

Beep Code	Descriptions
1 short	DRAM refresh failure
2 short	Parity circuit failure
3 short	Base 64K RAM failure
4 short	System timer failure
5 short	Process failure
6 short	Keyboard controller Gate A20 error
7 short	Virtual mode exception error
8 short	Display memory Read/Write test failure
9 short	ROM BIOS checksum failure
10 short	CMOS shutdown Read/Write error
11 short	Cache Memory error
1 long, 3 short	Conventional/Extended memory failure
3 long	DRAM absent

After BIOS reset, connect USB keyboard to printer then click 'DEL' key when power on. Go to 'BIOS Setup Utility' to set priority of hard driver. Make 'USB: USB Flash DRI' as the first priority and 'HDD: xx-xxxxxxx' as the last priority

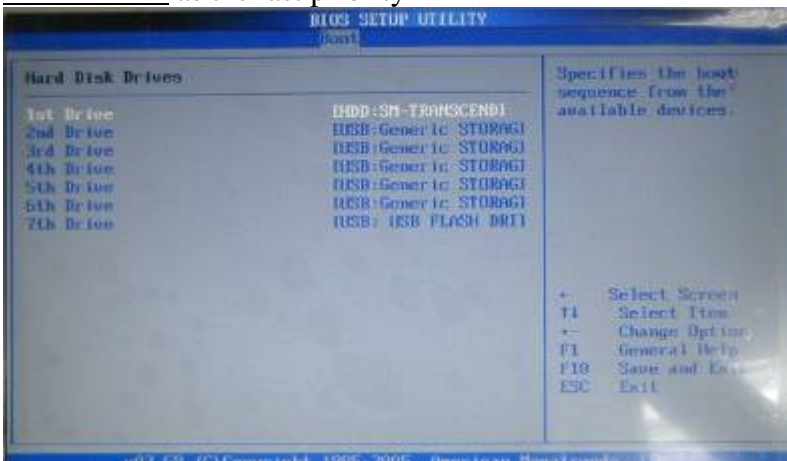

● **BIOS Update**

Make a USB boot disk by 'HP USB Disk Storage Format Tool'. Connect USB key board and memory card (save BIOS into memory card) to printer before power on. When seeing C:\>, key in 'cd HITI'. Key in 'Go' then click 'Enter' to start BIOS update when seeing C:\>HITI>.

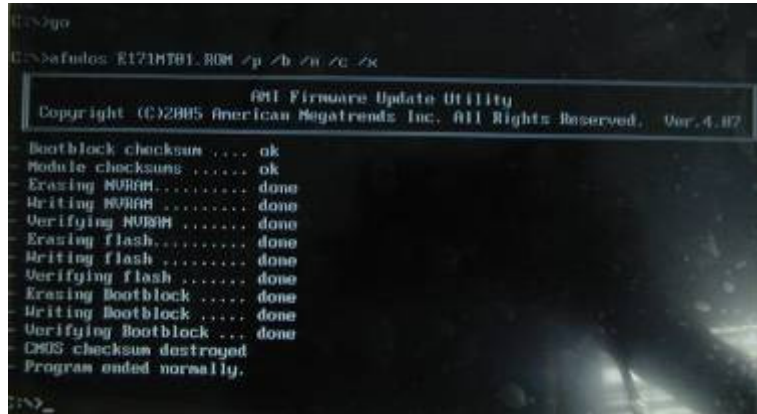
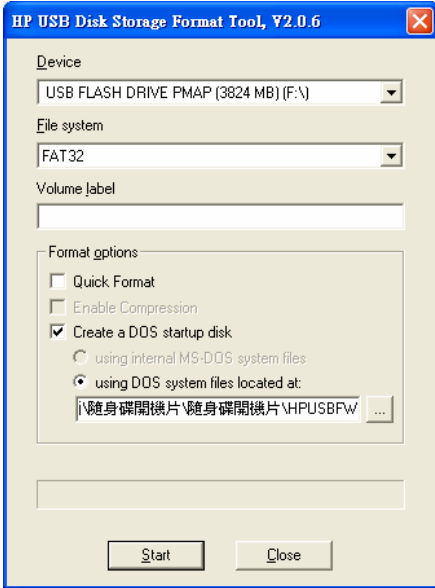

3-1-3 Card Board

Support	Type	
CF Card Slot		
SD Card Slot	3 in 1	MMC/ RS-MMC/ SD
XD Card Slot		
Micro SD Card Slot		T Flash/ Micro-SD
MS Micro Card Slot (M2)		
MS Card Slot	2 in 1	MS-Card/ MS Pro Card/ MS Duo Card/ MS Duo Pro Card
USB Slot		

3-1-4 Power Board

45W Dual Output Switching Power Supply

Model	PD-45A	
Output number	CH1	CH2
DC Voltage	5V	12V
Rated Current	3.2A	2A
Current Range	0.4~5A	0.2~2.5A

3-1-5 10.2" TFT LCD

10.2" color TFT-LCD module composed of LCD panel, driver ICs ,control circuit and backlight. By applying 1024×600 images are displayed on the 10.2" diagonal screen. Display 262K colors by 6 Bit R.G.B signal input.

General specification are summarized in the following table:

Item	Specification
Display Area (mm)	222.72 (H) x 130.5(V) (10.2-inch diagonal)
Number of Pixels	1024(H) x 3(RGB) x 600(V)
Pixel Pitch (mm)	0.2175(H) x 0.2175(V)
Color Pixel Arrangement	RGB vertical stripe
Display Mode	Normally white, TN
Number of Colors	262,144
Optimum Viewing Angle	6 o'clock
Brightness (cd/m²)	400 nit (typ)
Response Time (ms)	25 ms (typ)
Viewing Angle	120 degree (Horizontal) 110 degree (Vertical)
Power Consumption	1.5 W (typ)
Interface Connection	LVDS
Module Size (mm)	235 (W) x 145.8 (H) x 5.9 (D)
Module Weight (g)	385 g (Max)
Backlight Unit	CCFL
Surface Treatment	Anit-Glare

•3-1-6 eTurbo Touch Panel

- ◆ Active area :223mm x 134.2mm
- ◆ Chattering Time: 10 msec or less
- ◆ Linearity: ± 1.5% error or less for X and Y axis.
- ◆ Touch Control board CT-520TR/ Resolution : 2048 x 2048 /RS-232 serial communication.

3-2. Hardware – Printer

- **Main board (MAIN_BD)** adopts 30V from power board to control the motor driver ICs that drives the motors and the mechanisms. The main board also converts input from 30V to 5V and 3.3V by voltage regulators of ASIC to Memory, Video IC, and the I/Os.

Notes: There is no hardware adjustment required for the main board of printer; the ribbon sensors can be adjusted through special software device.



1. OEE ASIC – Print Engine

We call this the print engine because it's in charge of the motor and USB connection, all the printer operations.

- 1-1. **SDRAM for Print Engine.** This 32MB SDRAM is to be used as storing data buffer. The image file, print data, video frame are temporarily stored during operation.
- 1-2. **(On the back side) NOR Flash for Print Engine.** This 1MB flash memory stores the MCU code.

2. FPGA – ALTERA

This chip controls the TPH interface, Capstan motor, cutter door motor, and I/O.

3. USB2.0

This is the USB 2.0 IC chip.

- **Power board** (POWER BD) is an AC to DC power convert device. It generates 400W max, 30V, DC source to drive the printer. There is also no hardware adjustment required for the P510K power board; the printout density can be adjusted through special software device. (Please refer to Chapter 5 of this service guide adjustment instruction)



- **TPH Board** is an extended circuit board from main board that converts the 27V (+/- 10%) to the thermal print head.



● LED & Sensors

➤ LED

- ◆ Card reading LED (orange)–light up shows insert cards, blinking shows card reading.

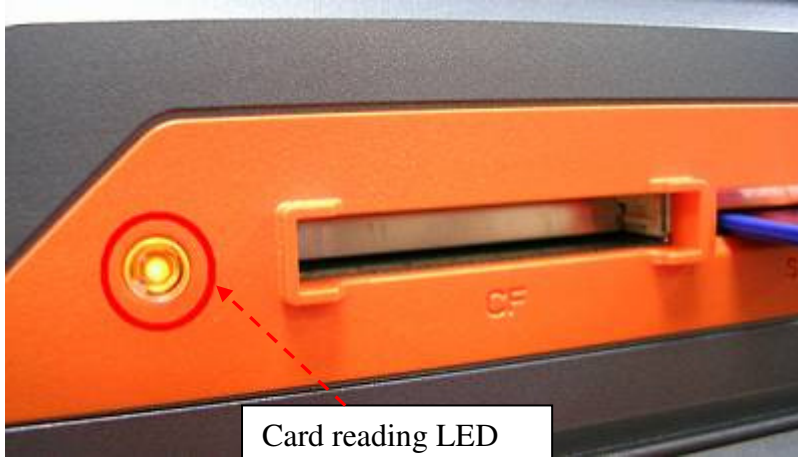

➤ Paper Sensors' function

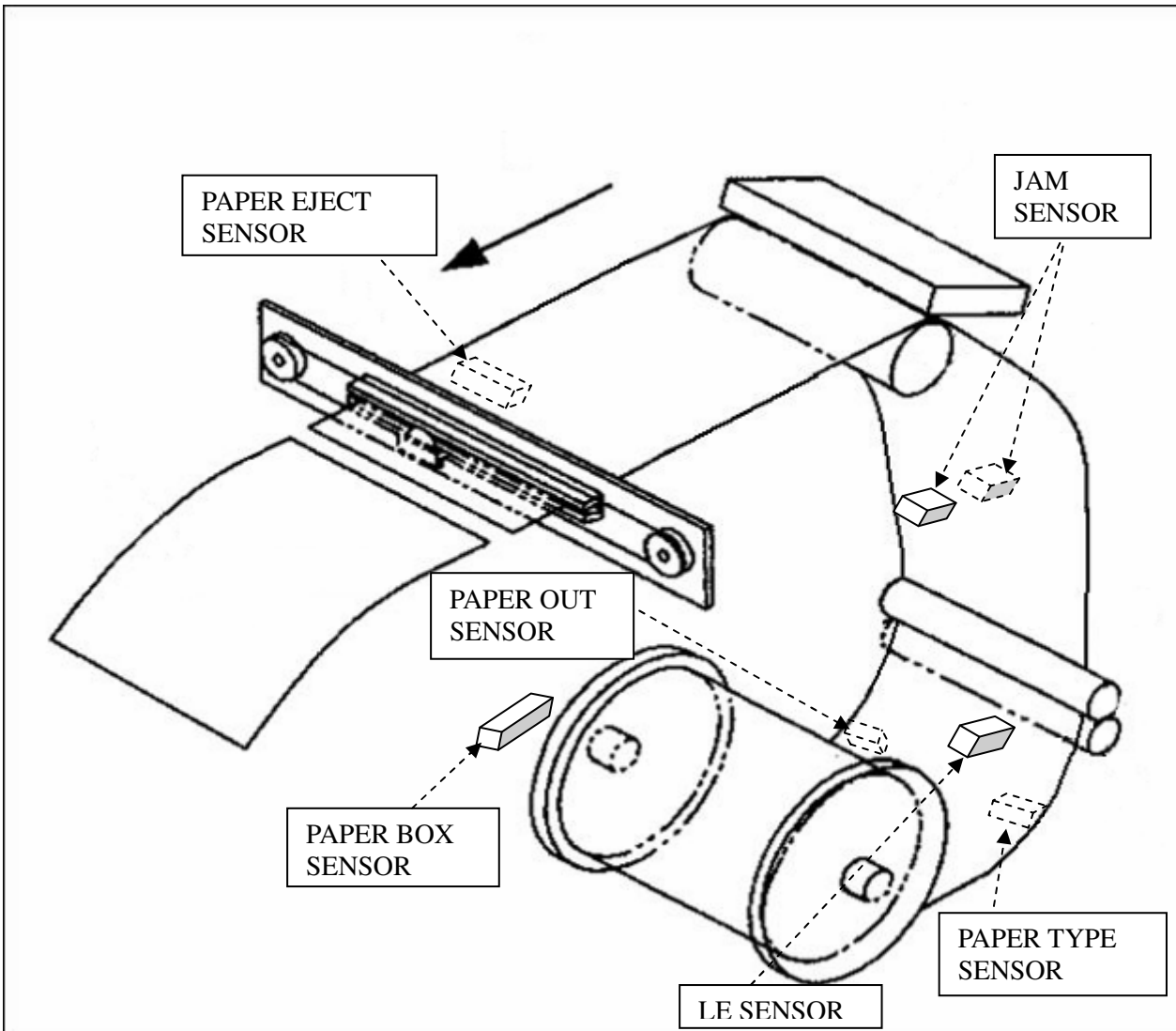

Sensor Type	Function	Activity Time	Error Message (Red LED blinking times)
PAPER_BOX_SNR 390MM BLUE	Detect paper box is well locked or not	When front cover closed, sensor will detect if paper box exist or not.	Paper Out (4)
WIRE PAPER_TYPE 590MM	Detect different paper types (6", 5")	After paper box sensor activated, paper type sensor will detect paper type.	Paper Mismatch (6)
WIRE PAPER_OUT 680MM	Detect paper position and if running out or not	After paper box sensor activated, paper out sensor will detect if paper appear or show error.	Paper Out (4)
WIRE LE_FEED_SNR 490MM	Detect the existence of paper and detect paper rolling back position	When load paper, detect paper exist and when the edge of paper passes sensor in paper rewind, printer will slow down the rolling speed.	Paper Out (4)
WIRE JAM_SNR 340MM	Detect the existence of paper and detect position where start to print	When print fails, paper jammed in printer, it will show error.	Paper Jam (5)
WIRE LE_EXIT_SNR 270MM	Detect paper size which would be cut	When printed finish, sensor will detect paper length which needed and cutting paper.	Paper Jam (5)

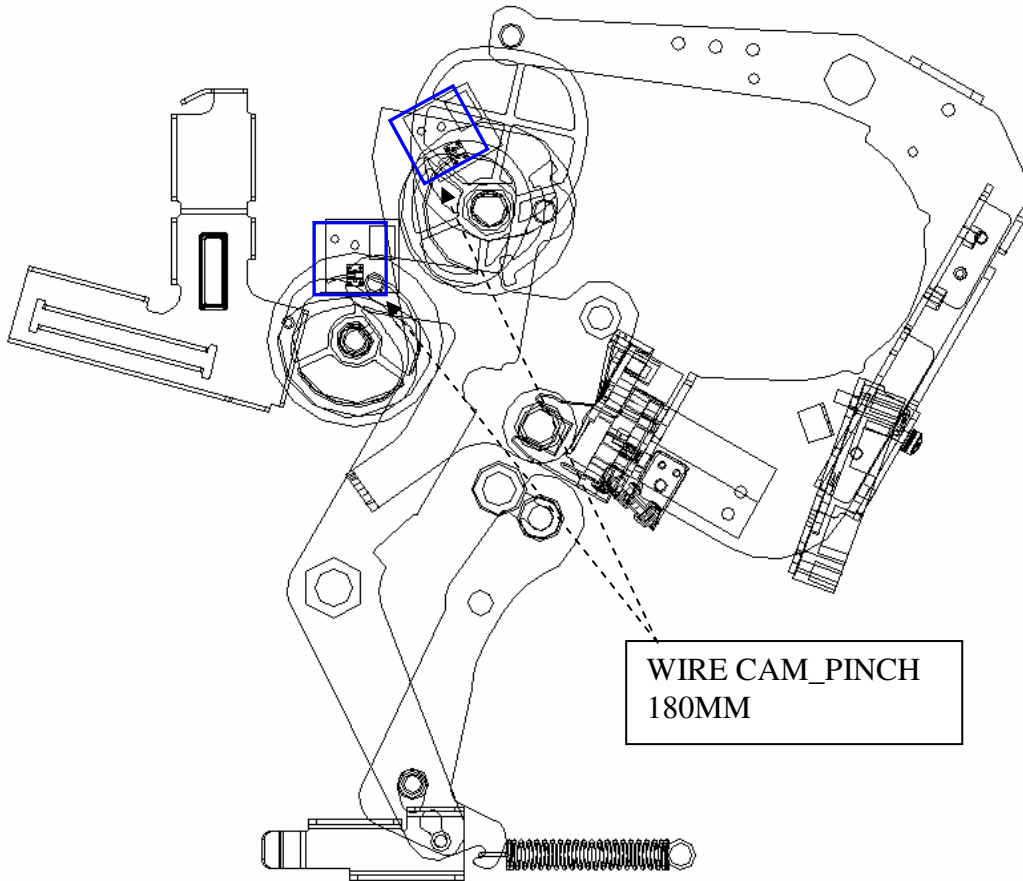

➤ **Cam Sensors function.**

Sensor Type	Function	Activity Time	Error Message (Red LED blinking times)
WIRE CAM_PINCH 180MM	Cam sensor (2 pcs) indicates the position of platen roller and pinch roller. There are three positions: P1 initial position, P2 load position, and P3 print position.	If sensors detects wrong positions in necessary conditions.	Cam Platen Error (7) OR Cam Pinch Error (8)

➤ **Cover and Chip Sensors' function**

These two sensors are visible without disassembling the machine. Please refer to assembly and disassembly for more details of how to replace them.

Sensor Type	Function	Activity Time	Error Message (Red LED blinking times)
WIRE DOOR_SNR 310MM	Detect front cover is well positioned or not	When front cover opens, printer will stop all actions and show error.	Cover Open (1)
WIRE SMART_CHIP 240MM	Detect ribbon type and sheet.	Sensor will detect if the area code match or not between ribbon and printer; and detect ribbon size type.	Ribbon Missing (2)

➤ **Ribbon LED/Sensor**

The P510K Ribbon LED/Sensor are different from other series, it's now an infrared sensor that only detects the black bars between each colors. Please also refer to assembly and disassembly for more details of how to replace them. There are totally 4 sets of items, including 2 LED and 2 sensors of left and right side. If one set of sensor is defective, the other set will automatically replace the defective one.

Sensor Type	Function	Activity Time	Error Message (Red LED blinking times)
WIRE RBN_LED_LEFT 350MM WIRE RBN_SNR_LEFT 120MM	Detect ribbon colors Y, M, C and O, which are index as black bar individually.	When ribbon can't be taken to correct position, it will show error.	Ribbon Out (3) OR Print Fail (N/A)
WIRE RBN_LED_RIGHT 470MM WIRE RBN_SNR_RIGHT 160MM			

Note: The status of printer while sensing ribbon

	Y	M	C	O
WIRE RBN_LED_LEFT 350MM WIRE RBN_SNR_LEFT 120MM	B	-	-	-
WIRE RBN_LED_RIGHT 470MM WIRE RBN_SNR_RIGHT 160MM	B	B	B	B

Black bar sample pictures on the ribbon cartridge



➤ **Sensor Types classification**

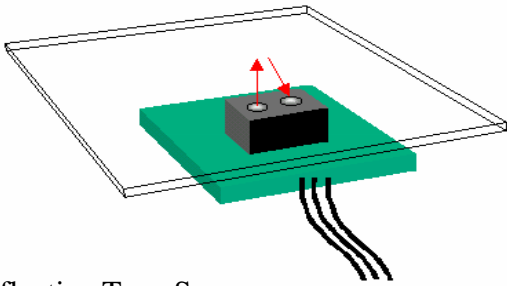

Reflective Type Sensor

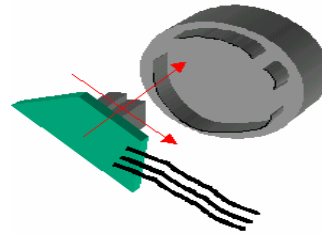

Penetration Type Sensor (Cam Sensor Type)

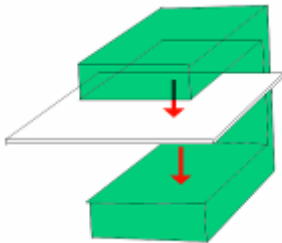

Penetration Type Sensor (Jam type sensor)

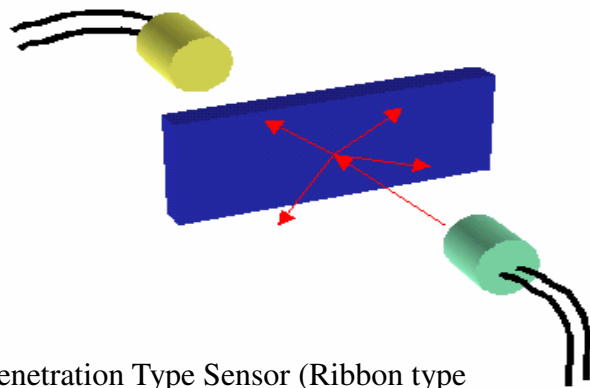

Penetration Type Sensor (Ribbon type sensor) LED and Sensor

● **Motors**

Motor Type	Function
MTR STEP_7.5_60HM_CAM_PLTN_200MM RED	Control the position of Cam Platen
MTR STEP_7.5_40HM_CAM_PINCH_90MM	Control the position of Cam Pinch
MTR STEP_1.8_2.4V_2.5A CAPSTON_250MM	Control the Capstan roller, move the paper forward and backward
MTR STEP_7.5_60HM_RBN_S_160MM ROHS	Control the ribbon supply side
MTR STEP_7.5_60HM_RBN_T_350MM	Control the ribbon take side
CUTTER_C104KZ (Module Set)	Control the cutter moving
MTR STEP_3.75_8.5OHM_PAPER_EXIT 240MM BL	Control the cutter door motions

Cam Platen Motor controls a set of cam gear that moves the platen roller toward the TPH (thermal print head) to start the dye diffusion thermal transfer process.

Cam Pinch Motor controls a set of cam gear that moves the pinch roller toward the capstan roller in order to produce enough attrition to move the paper to the printing position.

Ribbon Take Motor, as to its name, it winds the ribbon to the printing color.

Ribbon Reverse Motor provides the power of the reverse TQL that rewinds the ribbon backward.

Cutter Motor connects to a belt that pulls the cutter knife during separation of printout from the paper roll.

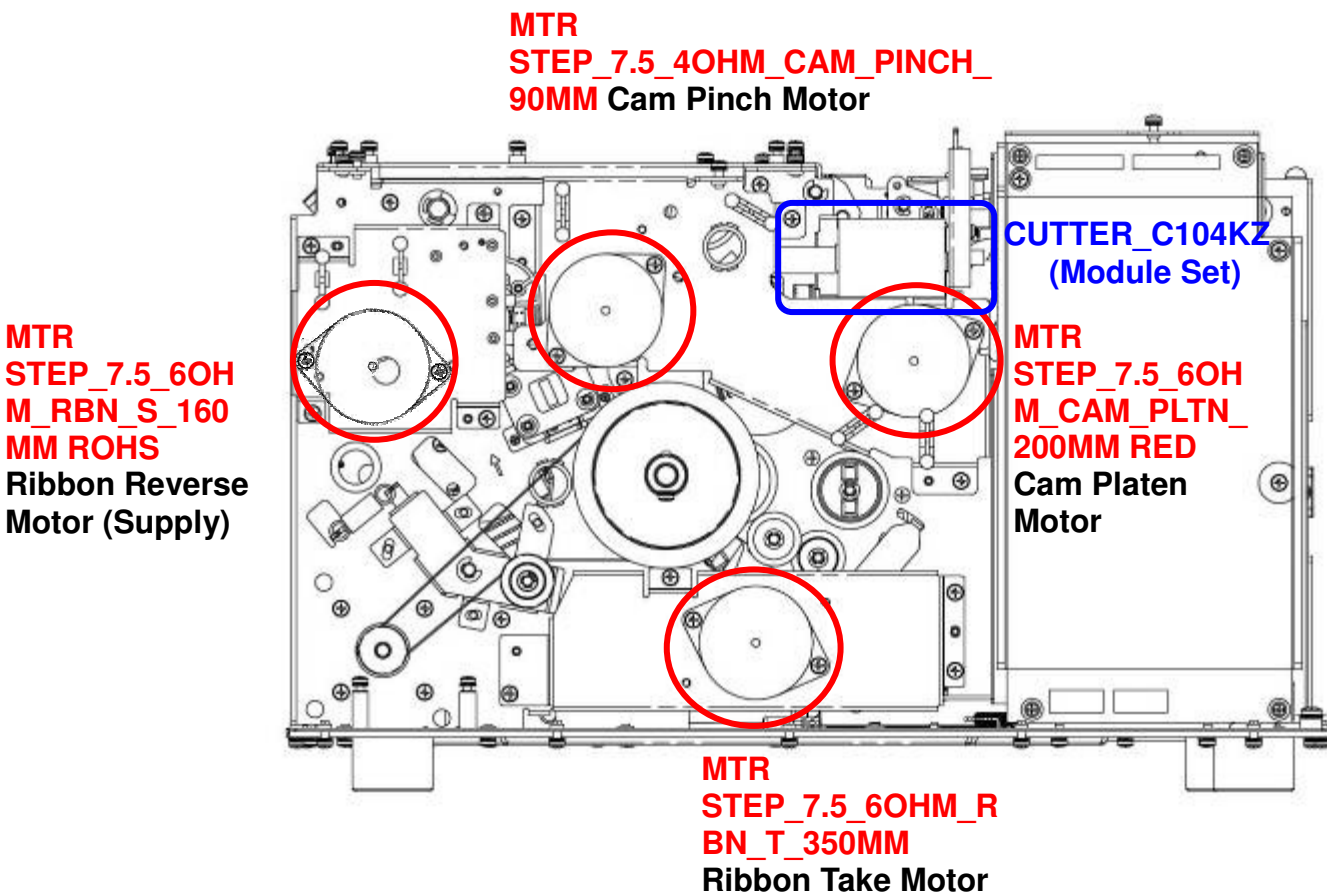

Cutter Door Motor controls the door that separates paper roll and it's left over scrap into the paper cassette.

MTR STEP_3.75_8.5OHM_PAPER_EXIT 240MM BL Cutter Door Motor

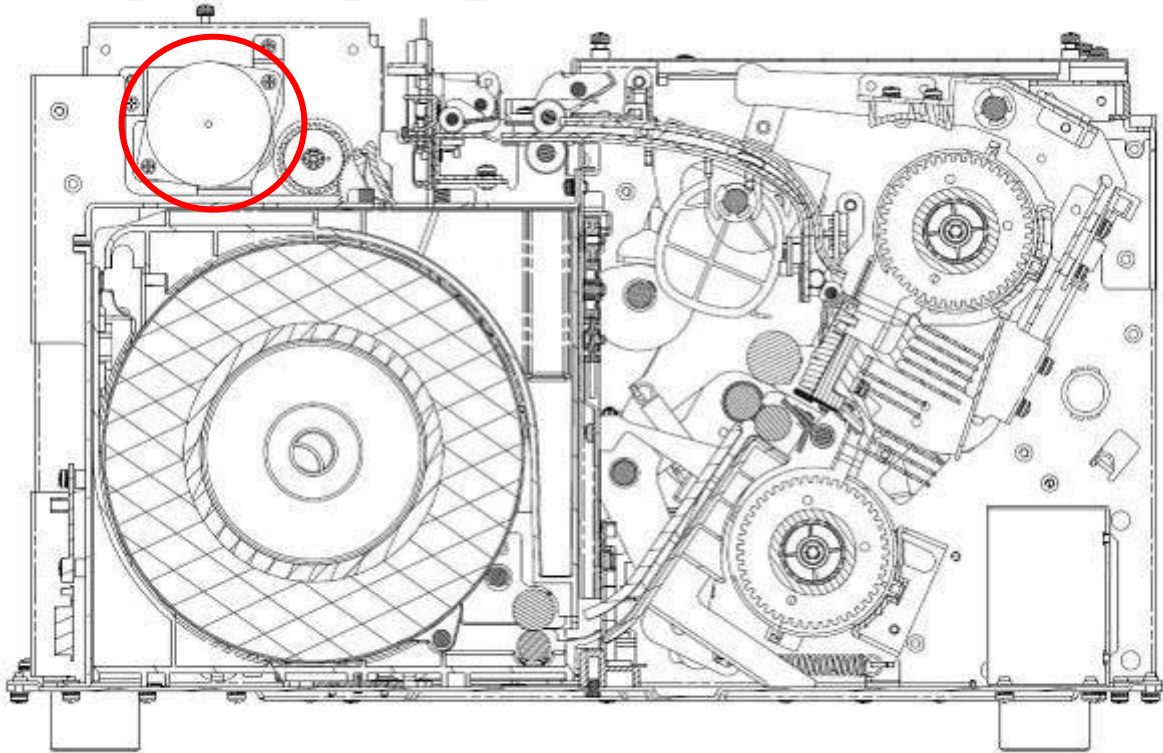

Capstan Motor is the most powerful motor in this printer; it controls the capstan roller through a belt and set of gears that controls the movement of the paper roll during printing process.

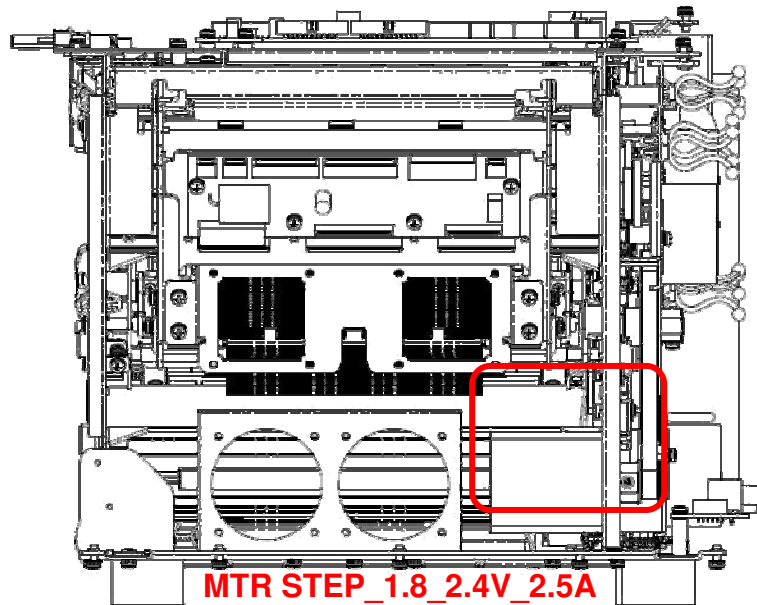

**MTR STEP_1.8_2.4V_2.5A
CAPSTON_250MM**

Capstan Motor

3-3. Printer Operation Chart

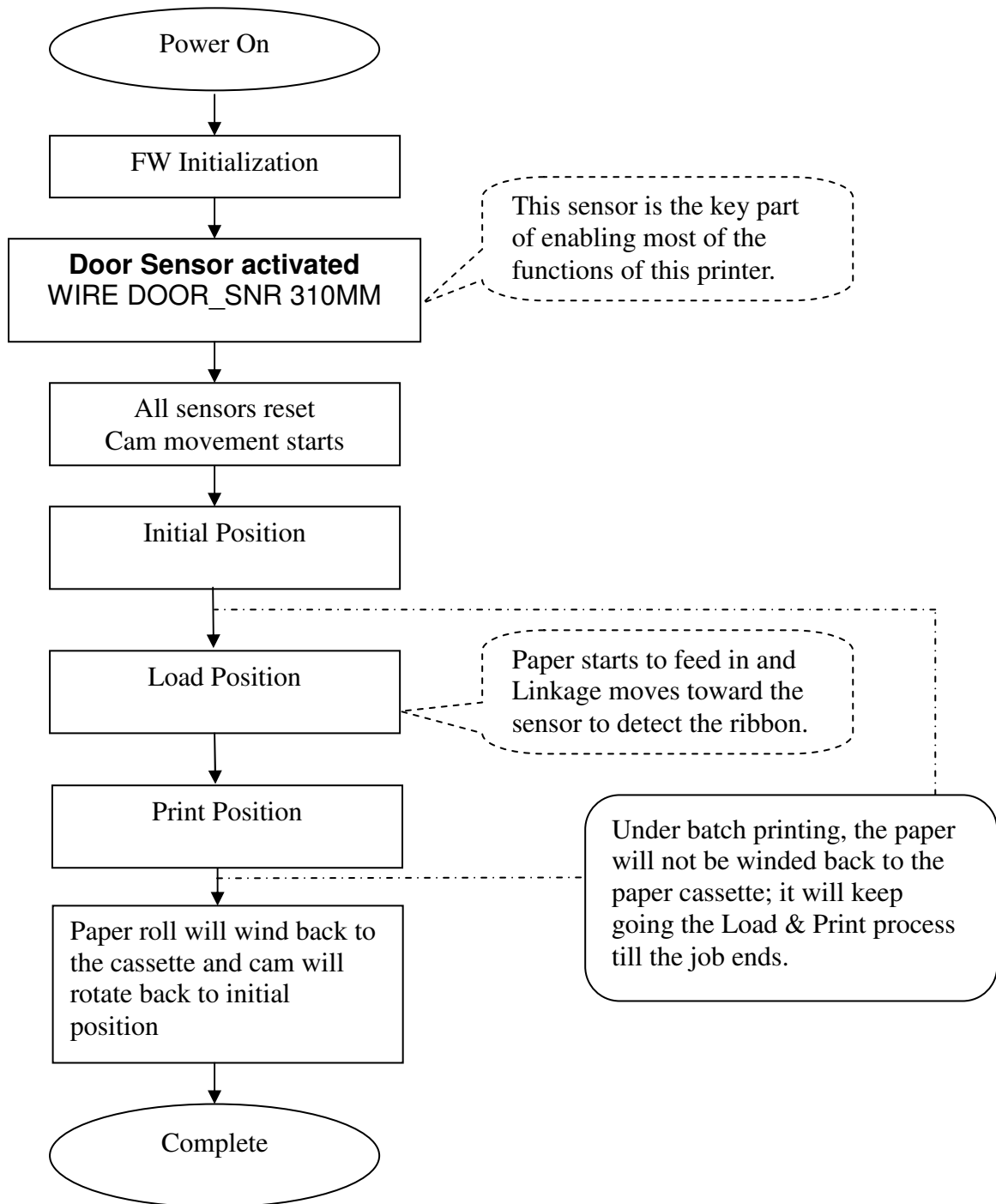

3-4. Mechanism & Movements

● Cam Motion – Initial

Q1 (cam platen position)

- ✓ Platen roller is in released position.

P1 (cam pinch position)

- ✓ Pinch roller is released from the capstan roller.
- ✓ Link_lock is released.
- ✓ TPH Linkage is widely opened.

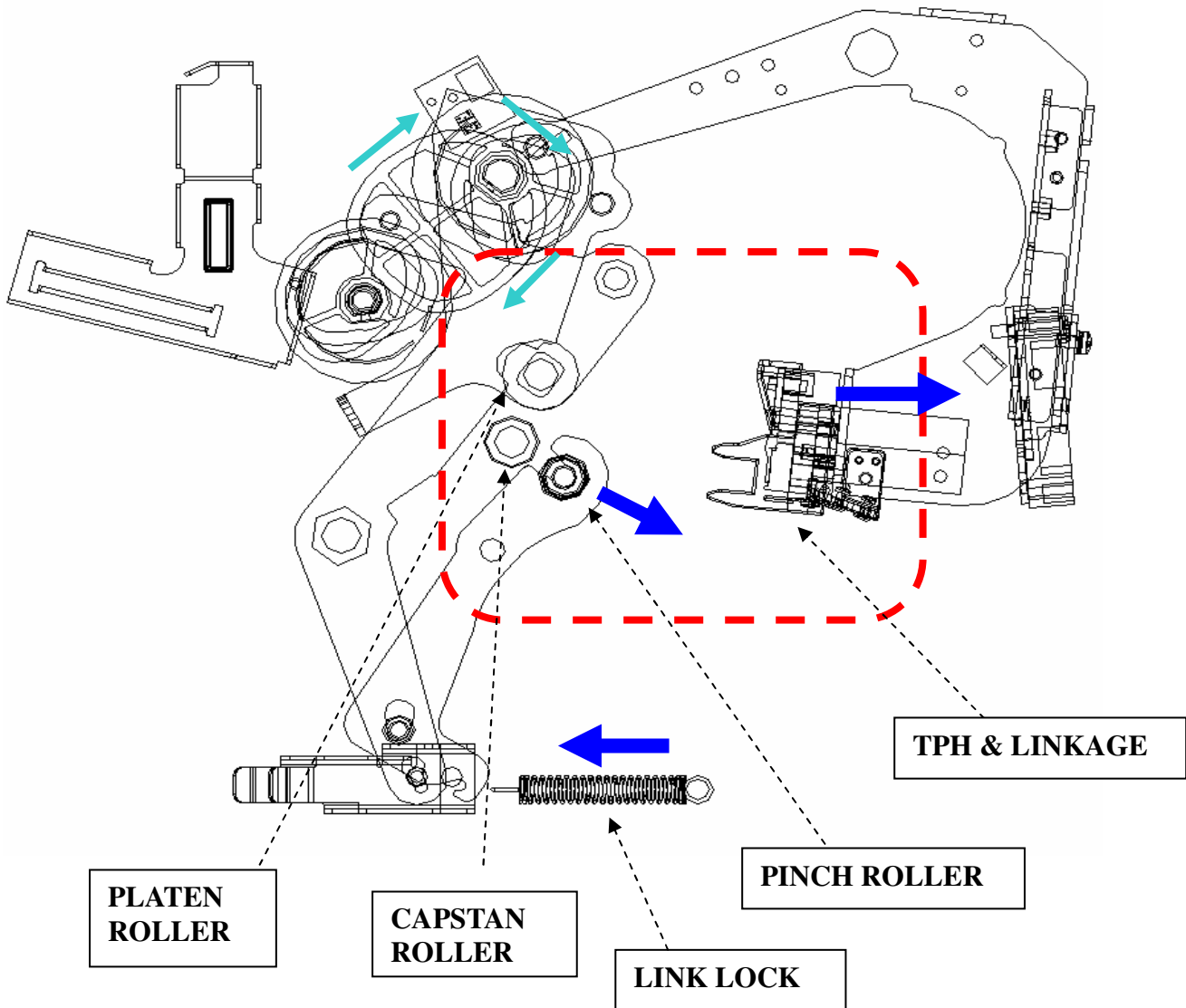

● Cam Motion –Load

Q1(cam platen position)

- ✓ Platen roller is still in released position.

P2 (cam pinch position)

- ✓ Pinch roller now is attached with the capstan roller.
- ✓ TPH is moved to active position but TPH is **not touching** the platen roller.
- ✓ Link_lock is activated so the Paper_Box cannot be taken away.

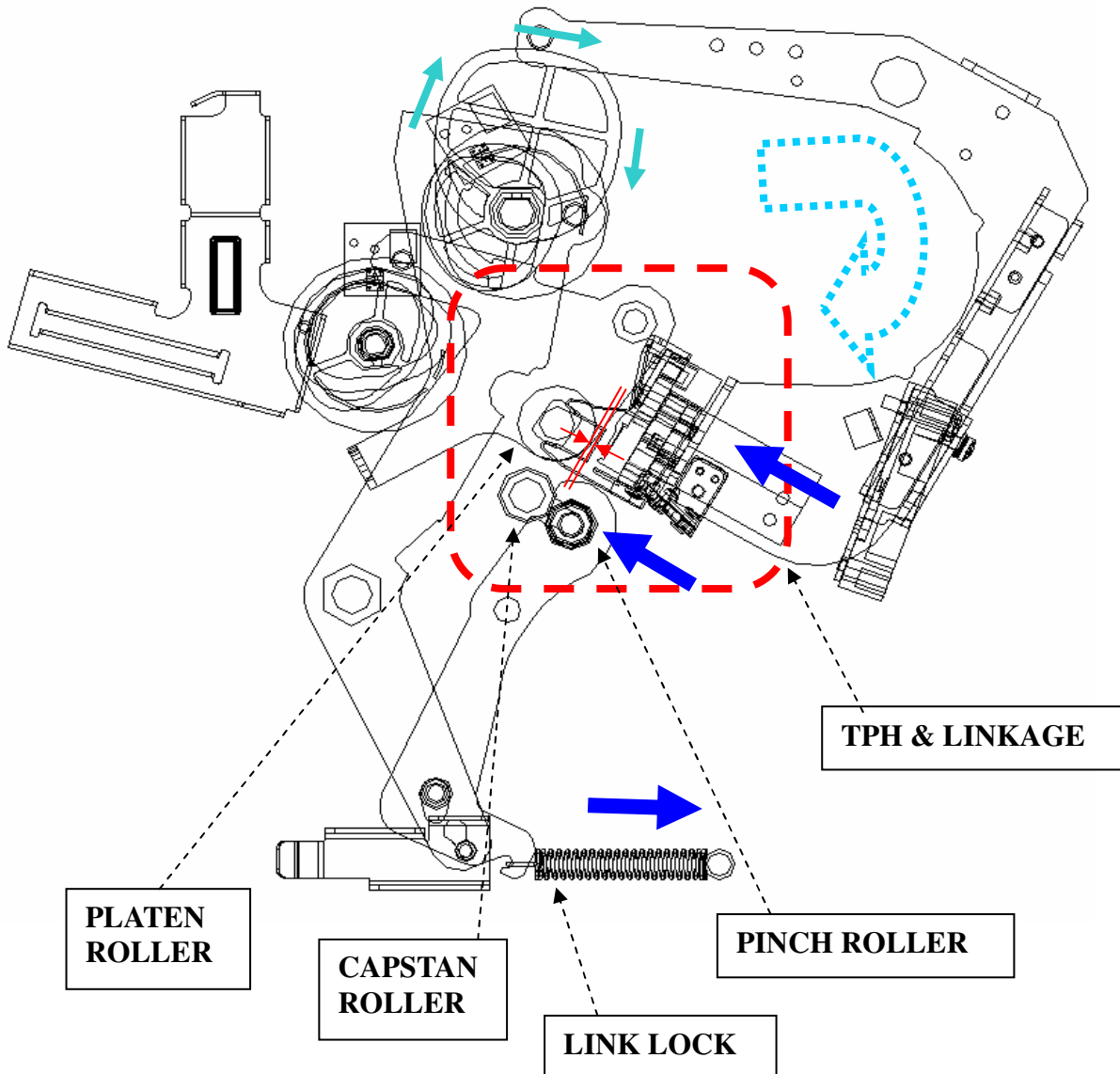

● Cam Motion – Print

Q2(cam platen position)

- ✓ CAM_PLATEN rotates, and cause LEVER_PLATEN rotates.
- ✓ Platen roller is now contacting with TPH.

P2 (cam pinch position)

- ✓ Pinch roller is still attached with the capstan roller.
- ✓ Link_lock is still activated so the Paper_Box cannot be taken away.
- ✓ TPH is still in active position and TPH is touching the platen roller.

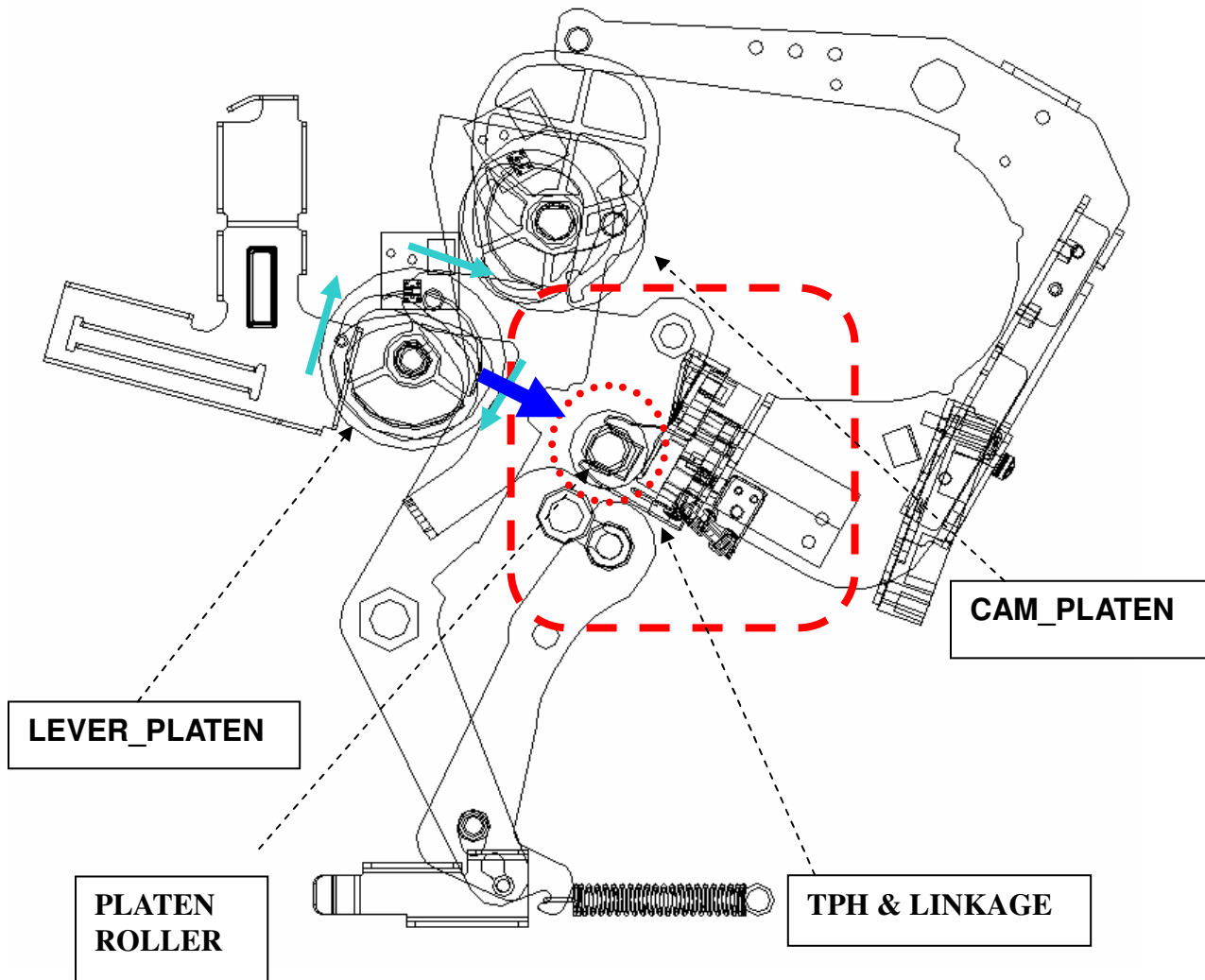

● Cam Motion –Cutting

Q3(cam platen position)

- ✓ CAM_PLATEN rotates, and caused LEVER_PLATEN rotates.
- ✓ Platen roller is released again.
- ✓ LINK_SEPARATION_PAPER_CUT shifts.

P2 (cam pinch position)

- ✓ Pinch roller is still attached with the capstan roller.
- ✓ Link_lock is still activated so the Paper_Box cannot be taken away.
- ✓ TPH is still in active position but TPH is not touching the platen roller.

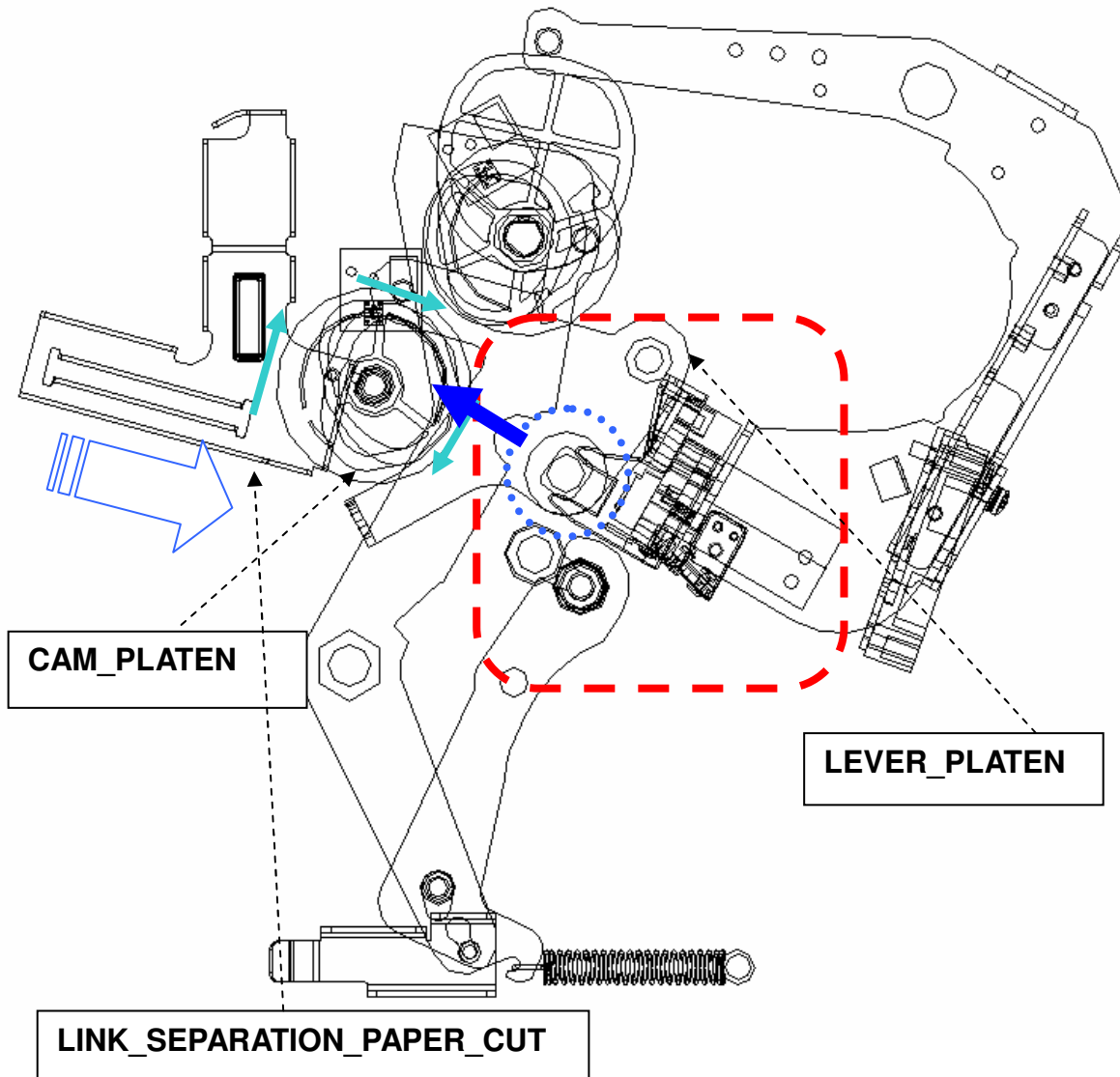

● Paper Path & Cutting

As shown below is the how the paper moves during printing process.

After the paper is being pulled out of roll and passed on to Pinch and Capstan Roller; these two rollers will grab the paper to the next printing stage

- 13 – Pinch Roller
- 14 – Capstan Roller
- 11 – TPH
- 12 – Platen Roller
- 10 – Paper Movement
- 19 – Cutter
- 21 – Printout

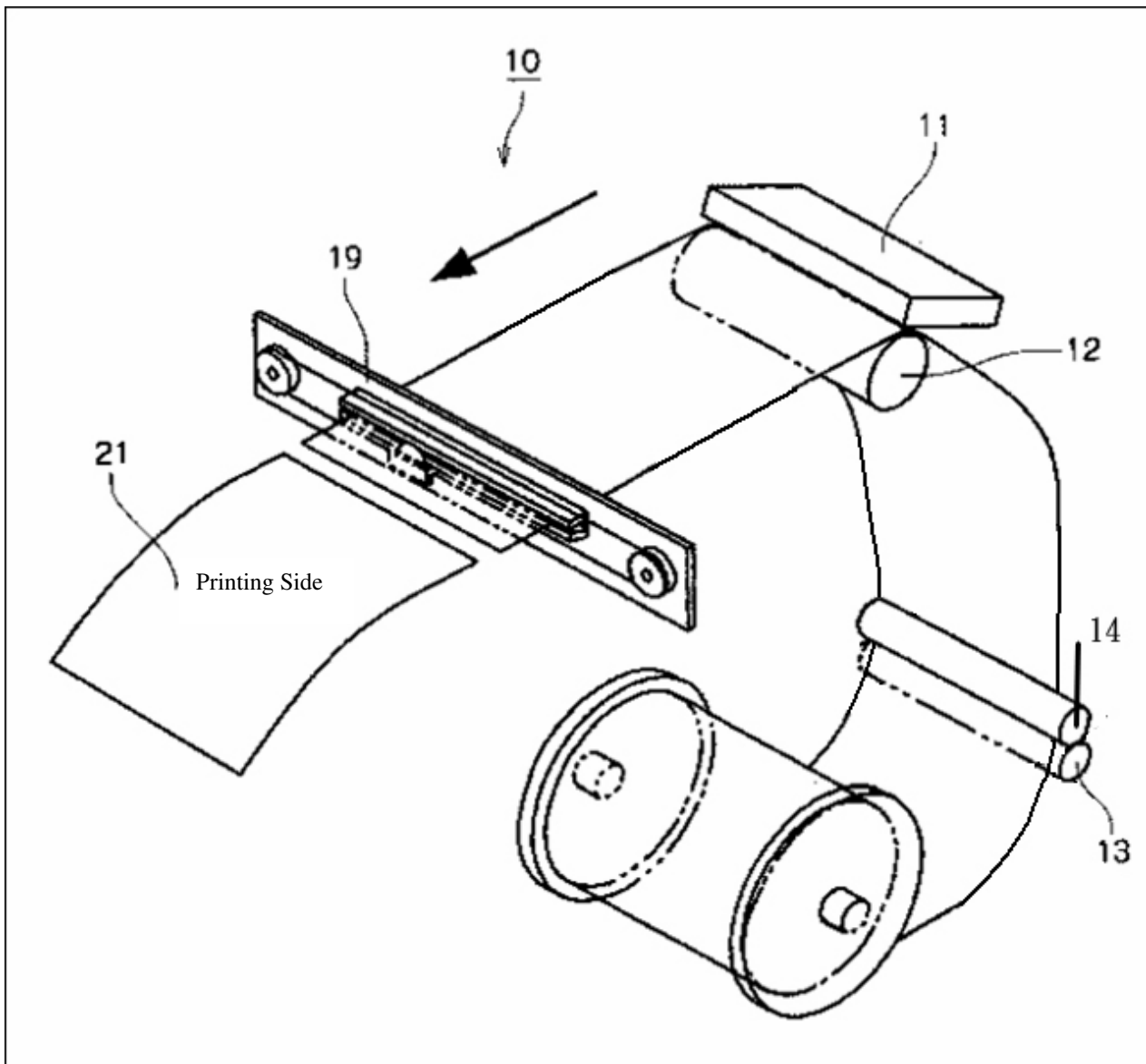

Chapter 4: Disassembly & Assembly

4-1 Tools Required

Name	Model	Q'ty
Phillips Screwdriver (#2)	#2	1
Screwdriver (small)	-	1
Flat-blade screwdriver (small)	2.5×100	1
Spring hook	-	1
Nipper	-	1
Pliers	-	1

4-2 Prohibition

The cutter and thermal print head are prohibited to disassemble; it requires special aligning equipments that is only available in the manufacturer’s factory. Any improper artificial alignment would affect its performance, and will be judged as “Out-Of-Warranty” (Pay for repair).

Do not turn loose or remove the screws shown below.

(1) Thermal Print Head

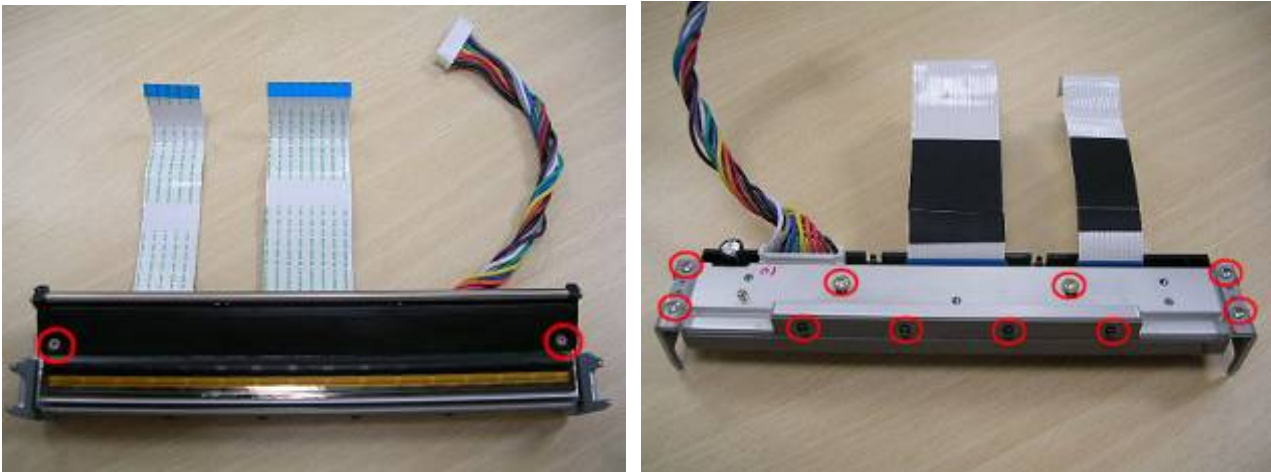

(2) Cutter



4-3 Precaution

Be sure to take necessary precaution of anti-static, or the LCD-Positioning system might be damaged. Thus a re-positioning action will have to be taken.

Go to configuration page and click the “Touch screen adjustment” to adjust touch screen if necessary.

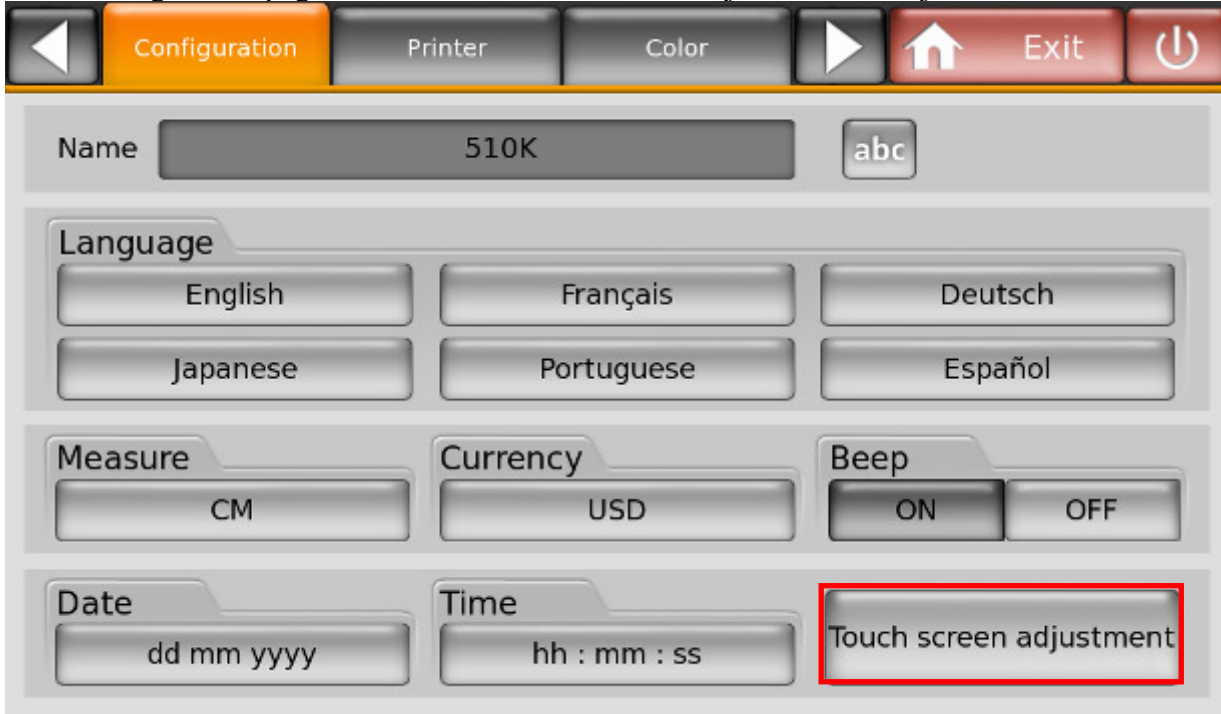

Follow the instructions to adjust the screen step by step.

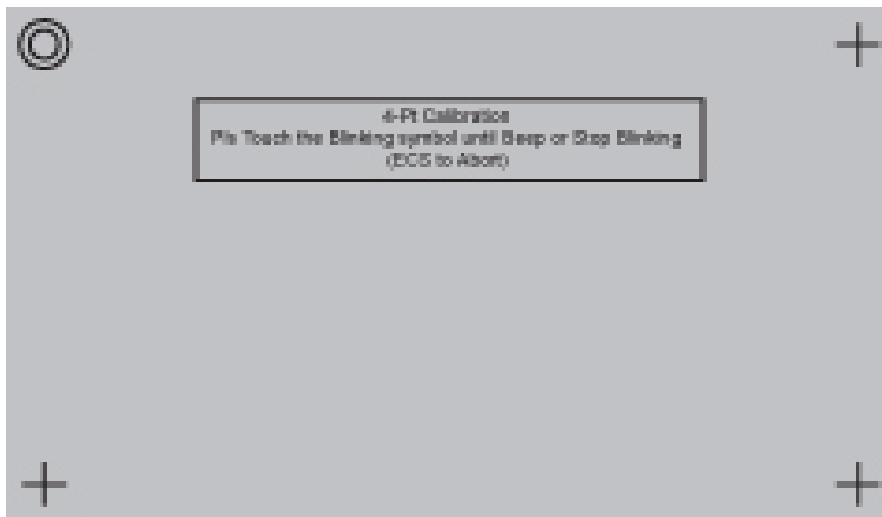

4-4 Parts Replacement Procedure

4-4-1 MAIN COVER REMOVAL PROCEDURE

Parts Name	1. ID_CASE_BACK_P510K 2. ID_COVER_MB_TOP_P510K 3. ID_CASE_TOP_P510K 4. ID_CASE_TOP_FRONT_P510K 5. ASSY LCD MODULE+ID CASE TOP+DECORATION 6. ASSY_CARD_READER 7. ID_CASE_RIGHT_P510K 8. ID_DOOR_RIGHT_P510K 9. ID_CASE_LEFT_P510K	Part No.	1. 56.D1002.011 2. 56.D1006.001 3. 56.D1005.001 4. 56.D1007.001 5. 48.D1008.001 6. 48.D1015.001 7. 56.D1003.011 8. 56.D1004.011 9. 56.D1001.011
Tools	Phillips screwdriver (#2), screwdriver (small)	Procedure No.	1

Maintenance Parts:

- 1. ID_CASE_BACK_P510K (CASE_BACK) Back Side
- 2. ID_COVER_MB_TOP_P510K (COVER_TOP) Top Side
- 3. ID_CASE_TOP_P510K (CASE_TOP_CASE) Top Side
- 4. ID_CASE_TOP_FRONT_P510K (TOP_FRONT_CASE) Front Side
- 5. ASSY LCD MODULE+ID CASE TOP+DECORATION (LCE MODULE) Top Side
- 6. ASSY_CARD_READER (CARD MODULE)Right Side
- 7. ID_CASE_RIGHT_P510K (CASE_RIGHT) Right Side
- 8. ID_DOOR_RIGHT_P510K (DOOR_RIGHT) Right Side
- 9. ID_CASE_LEFT_P510K (CASE_LEFT) Left Side

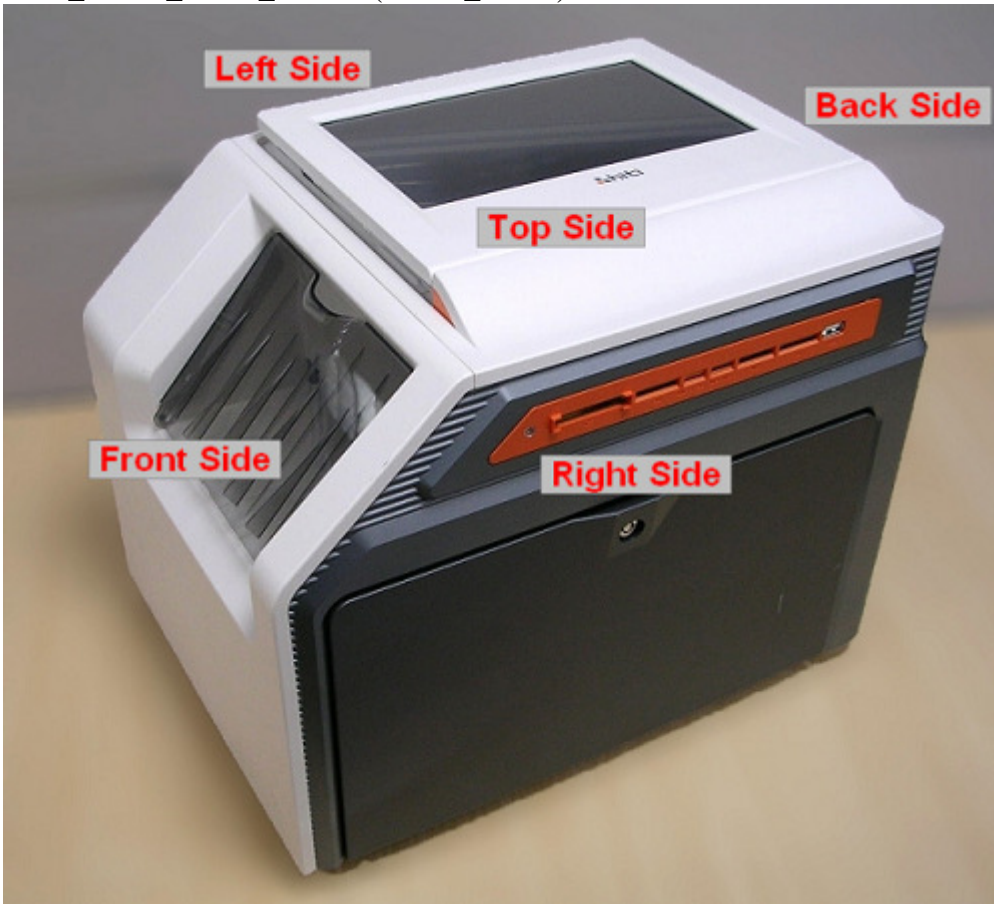

[Step 1] Turn the printer to the back side then remove 3 screws from the bottom, and then slide down the “ID_CASE_BACK_P510K”.



ID_CASE_BACK_P510K

[Step 2] Flip up the “ASSY LCD MODULE+ID CASE TOP+DECORATION “ then remove 4 screws to take out the “ID_COVER_MB_TOP_P510K”.

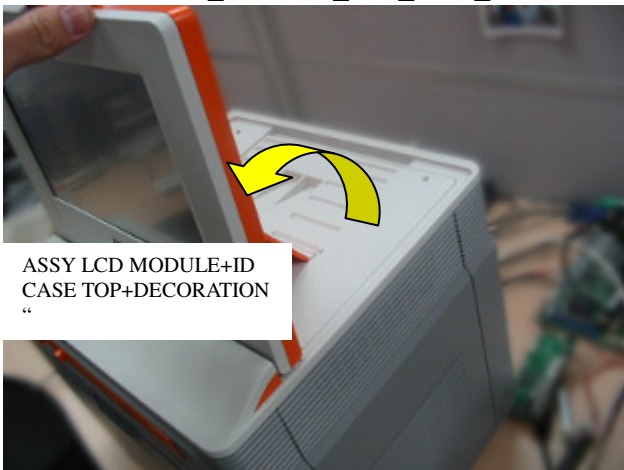

ASSY LCD MODULE+ID
CASE TOP+DECORATION
“



ID_COVER_MB_TOP_P510K

[Step 3] Remove 2 screws that hold the “ID_CASE_TOP_P510K” then turn the printer to the front side, and then remove 3 screws from the bottom of “ID_CASE_TOP_FRONT_P510K”.



ID_CASE_TOP_P510K



ID_CASE_TOP_FRONT_
P510K

[Step 4] Remove 3 connectors and 1 ground which are marked.



Slide and remove the "ID_CASE_TOP_P510K" and "ID_CASE_TOP_FRONT_P510K" together with "ASSY LCD MODULE+ID CASE TOP+DECORATION" as direction



NOTE:

1. Remove 4 screws then you can separate "ID_CASE_TOP_FRONT_P510K" and "ASSY LCD MODULE+ID CASE TOP+DECORATION".



2. Remove 4 screws then you can separate "ID_CASE_TOP_P510K" and "ID_CASE_TOP_FRONT_P510K".



[Step 5] Remove 3 screws and 2 connectors to take “ASSY_CARD_READER” out.

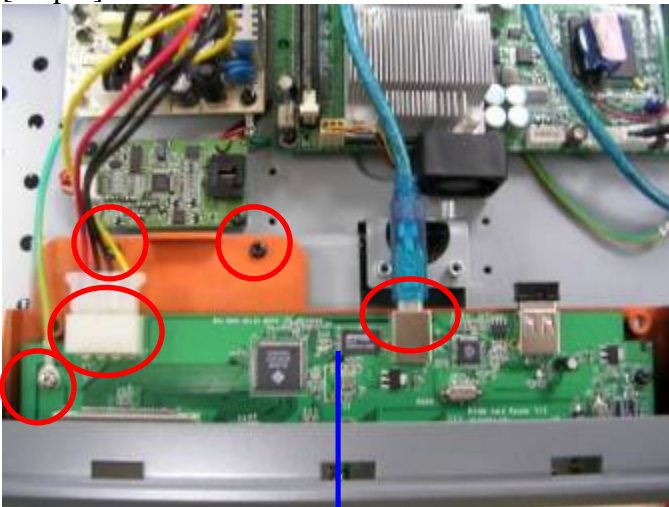

[Step 6] Turn the printer to the bottom side. Remove 2 screws from right side (“ID_CASE_RIGHT_P510K”). Remove 5 screws from left side (“ID_CASE_LEFT_P510K”).

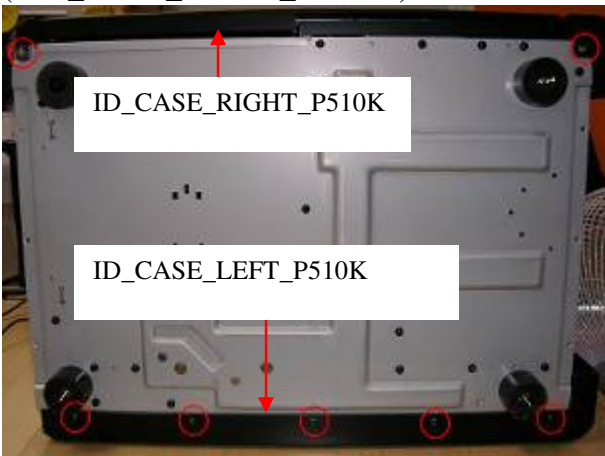

[Step 7] Turn the printer to the right side. Open the “ID_DOOR_RIGHT_P510K” then remove 6 screws to take out the “ID_CASE_RIGHT_P510K”, and then the “ID_DOOR_RIGHT_P510K”.



[Step 8] Turn the printer to the left side. Remove 2 screws.



[Step 9] Remove 4 connectors.

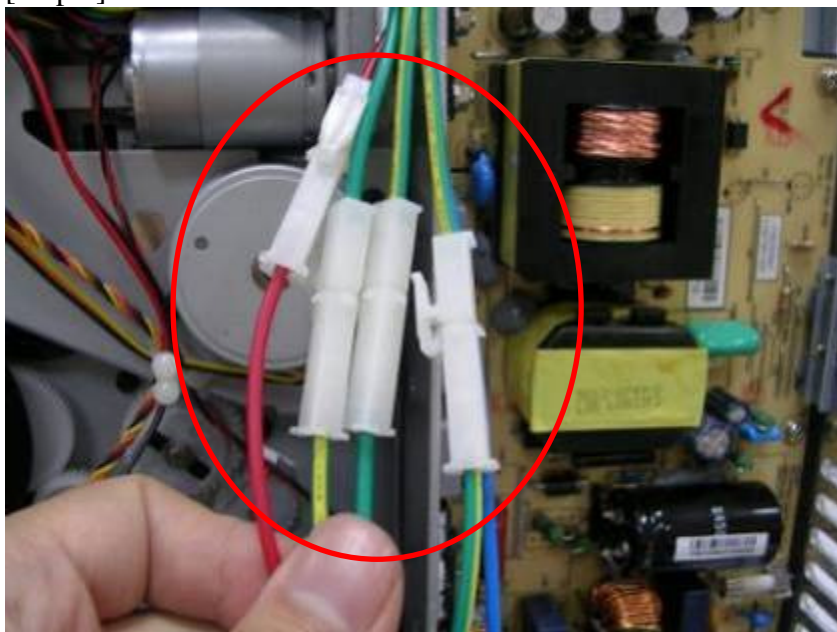

[Step 10] Remove the 2 connectors of “POWER BD P510S 002 ROHS” and 1 connector from the “POWER BD P510K TO KIOSK SYSTEM”.

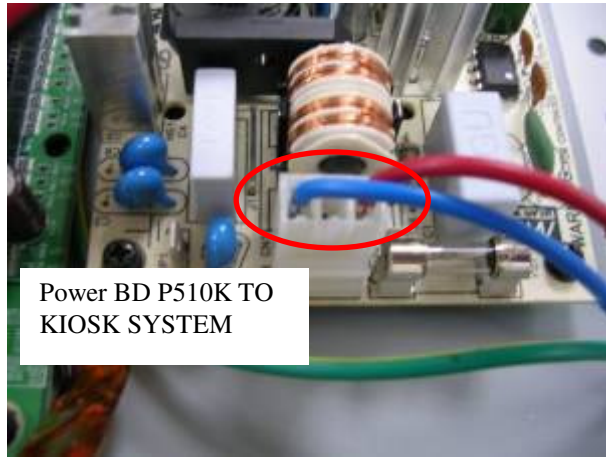

[Step 11] Remove the connector of fan and then take out the “ID_CASE_LEFT_P510K”.

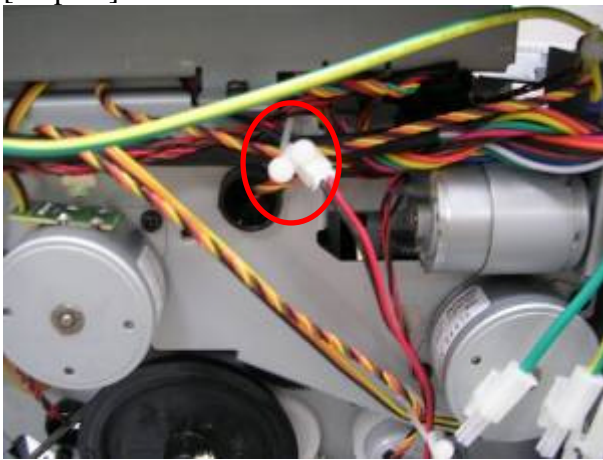

4-4-2 P510K PHOTO PRINTER KIOSK M/B

Parts Name	P510K PHOTO PRINTER KIOSK M/B	Part No.	44.001R1.001
Tools	Phillips screwdriver (#2), screwdriver (small)	Procedure No.	2

Maintenance Parts: P510K PHOTO PRINTER KIOSK M/B (KIOSK MAIN BOARD)

[Step 1] Remove the “ID_CASE_BACK_P510K”, “ID_COVER_MB_TOP_P510K”, “ID_CASE_TOP_P510K”, “ID_CASE_TOP_FRONT_P510K”, “ASSY LCD MODULE+ID CASE TOP+DECORATION “ according to the **“Procedure No. 1”** step 1 to step 4 .

[Step 2] Remove all connectors of “P510K PHOTO PRINTER KIOSK M/B”. Remove 4 screws that hold the “P510K PHOTO PRINTER KIOSK M/B” then take out the “P510K PHOTO PRINTER KIOSK M/B”.

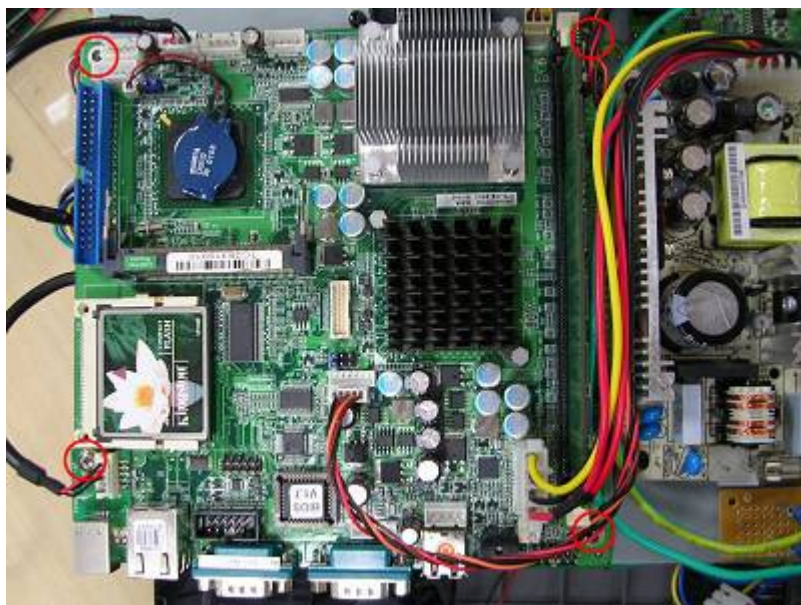
Note:

Please confirm that all the connectors are securely connected to “P510K PHOTO PRINTER KIOSK M/B” while doing assembly.

4-4-3 POWER BD P510K TO KIOSK SYSTEM

Parts Name	POWER BD P510K TO KIOSK SYSTEM	Part No.	44.O01R2.001
Tools	Phillips screwdriver (#2), screwdriver (small)	Procedure No.	3

Maintenance Parts: POWER BD P510K TO KIOSK SYSTEM (KIOSK POWER BOARD)



[Step 1] Remove the “ID_CASE_BACK_P510K”, “ID_COVER_MB_TOP_P510K”, “ID_CASE_TOP_P510K”, “ID_CASE_TOP_FRONT_P510K”, “ASSY LCD MODULE+ID CASE TOP+DECORATION “ according to the **“Procedure No. 1”** step 1 to step 4 .

[Step 2] Remove 1 connector of “POWER BD P510K TO KIOSK SYSTEM”. Remove 4 screws that hold the “POWER BD P510K TO KIOSK SYSTEM” then take out the “POWER BD P510K TO KIOSK SYSTEM”.

Note:

Please confirm that all the connectors are securely connected to “POWER BD P510K TO KIOSK SYSTEM” while doing assembly.

4-4-4 FRAME_MID_P510K

Parts Name	FRAME_MID_P510K	Part No.	51.D1006.004
Tools	Phillips screwdriver (#2), screwdriver (small)	Procedure No.	4

Maintenance Parts: MAIN_FRAME

[Step 1] Remove the “ID_CASE_BACK_P510K”, “ID_COVER_MB_TOP_P510K”, “ID_CASE_TOP_P510K”, “ID_CASE_TOP_FRONT_P510K”, “ASSY LCD MODULE+ID CASE TOP+DECORATION”, “ASSY_CARD_READER”, “ID_CASE_RIGHT_P510K”, “ID_DOOR_RIGHT_P510K”, “ID_CASE_LEFT_P510K”, “P510K PHOTO PRINTER KIOSK M/B” and “POWER BD P510K TO KIOSK SYSTEM” according to [Procedure No. 1, 2 and 3](#).

[Step 2] Remove 5 screws to take out the “FRAME_MID_P510K”.

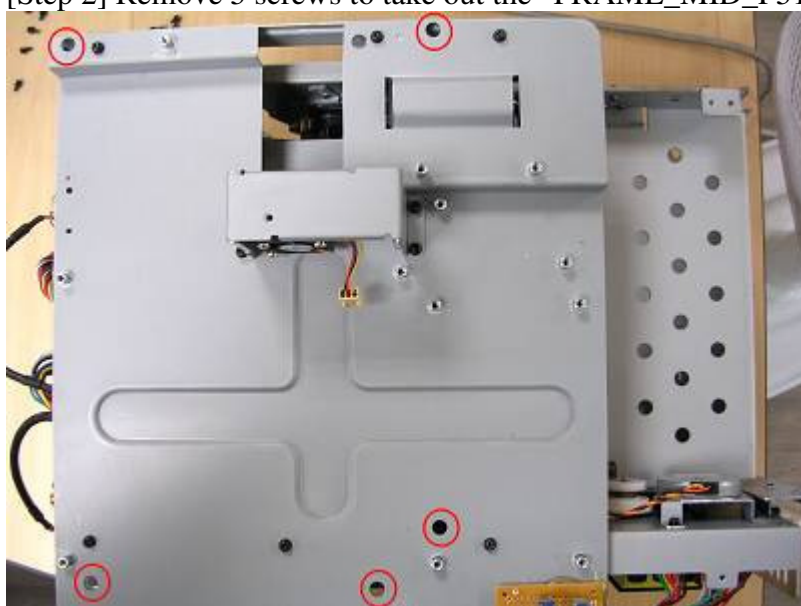

4-4-5 MAIN_BD P510K 011 ROHS

Parts Name	MAIN_BD P510K 011 ROHS	Part No.	45.D10R1.011
Tools	Phillips screwdriver (#2), screwdriver (small)	Procedure No.	5

Maintenance Parts: MAIN_BD P510K 011 ROHS (PRINTER MAIN BOARD)

[Step 1] Remove the “ID_CASE_BACK_P510K”, “ID_COVER_MB_TOP_P510K”, “ID_CASE_TOP_P510K”, “ID_CASE_TOP_FRONT_P510K”, “ASSY LCD MODULE+ID CASE TOP+DECORATION”, “ASSY_CARD_READER”, “ID_CASE_RIGHT_P510K”, “ID_DOOR_RIGHT_P510K”, “ID_CASE_LEFT_P510K”, “P510K PHOTO PRINTER KIOSK M/B”, “POWER BD P510K TO KIOSK SYSTEM” and “FRAME_MID_P510K” according to **Procedure No. 1, 2, 3 and 4**.

[Step 2] Remove all connectors of “MAIN_BD P510K 011 ROHS”. Remove 4 screws to take out the “MAIN_BD P510K 011 ROHS”.

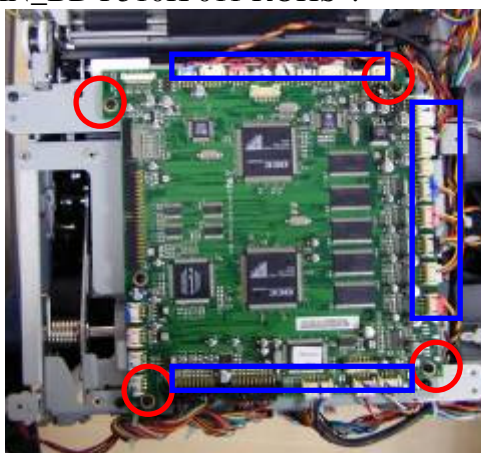
Note:

Please confirm that all the connectors are securely connected to “MAIN_BD P510K 011 ROHS” while doing assembly.

4-4-6 POWER BD P510 002 ROHS

Parts Name	POWER BD P510 002 ROHS	Part No.	44.D09R2.002
Tools	Phillips screwdriver (#2), screwdriver (small)	Procedure No.	6

Maintenance Parts: PCB TPH_BD P510 041 ROHS (PRINTER POWER BOARD)



[Step 1] Remove the “ID_CASE_LEFT_P510K” according to [Procedure No. 1](#) step 6, 8, 9, 10 and 11.

[Step 2] Remove 4 screws and unplug 2 connectors to take out the “POWER BD P510 002 ROHS”.



Note:

Please confirm that all the connectors are securely connected to “POWER BD P510 002 ROHS” while doing assembly.

4-4-7 PCB TPH_BD P510 041 ROHS

Parts Name	PCB TPH_BD P510 041 ROHS	Part No.	45.D09R6.031
Tools	Phillips screwdriver (#2)	Procedure No.	7

Maintenance Parts: PCB TPH_BD P510 041 ROHS (TPH BOARD)

[Step 1] Remove the “ID_CASE_BACK_P510K” according to **Procedure No. 1 step 1**.

[Step 2] Remove 4 screws and unplug all wires/cables to take out the “PCB TPH_BD P510 041 ROHS”.

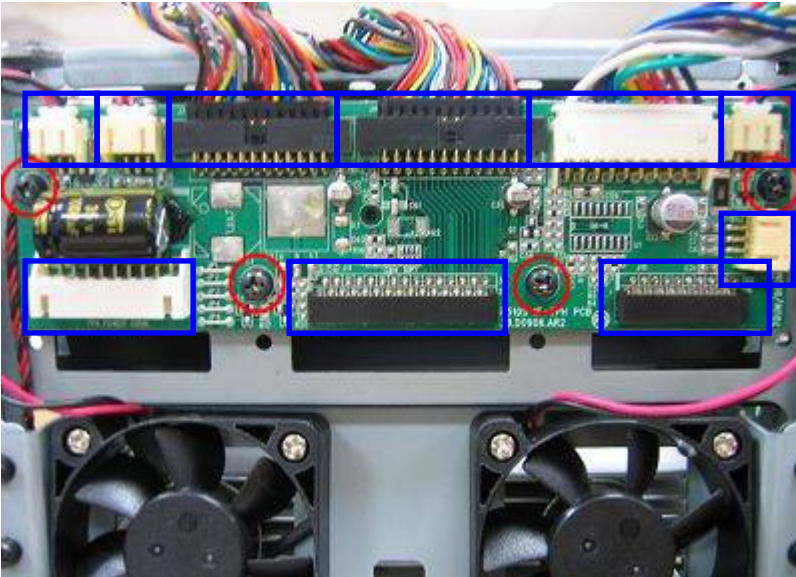
Note:

1. Please confirm that all the wires are securely connected to “PCB TPH_BD P510 041 ROHS” while doing assembly. Put hot glue to fix wires accordingly. Improper installation will cause abnormal printout.
2. Please install “FLAT CABLE 20P P1.0 110MM DP ROHS” carefully. Defective cable will cause abnormal printout as well.

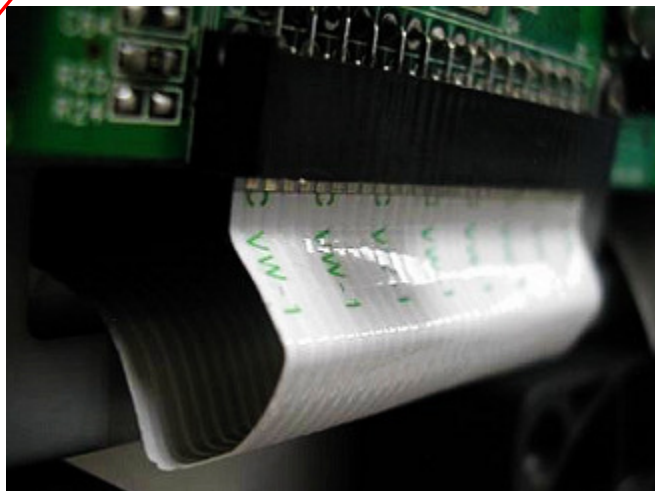
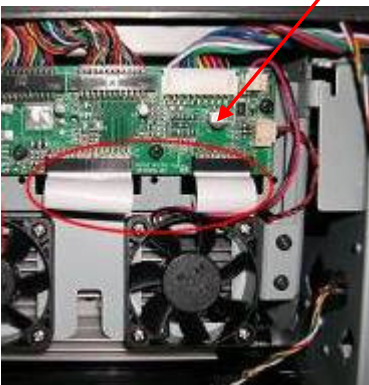

4-4-8 MTR STEP_7.5_6OHM_RBN_S_160MM ROHS

Parts Name	MTR STEP_7.5_6OHM_RBN_S_160MM ROHS	Part No.	17.MKD09.BN1
Tools	Phillips screwdriver (#2), screwdriver (small)	Procedure No.	8

Maintenance Parts: MTR STEP_7.5_6OHM_RBN_S_160MM ROHS (RIBBON REVERSE MOTOR)



[Step 1] Remove the “ID_CASE_BACK_P510K”, “ID_COVER_MB_TOP_P510K”, “ID_CASE_TOP_P510K”, “ID_CASE_TOP_FRONT_P510K”, “ASSY LCD MODULE+ID CASE TOP+DECORATION”, “ASSY_CARD_READER”, “ID_CASE_RIGHT_P510K”, “ID_DOOR_RIGHT_P510K”, “ID_CASE_LEFT_P510K”, “P510K PHOTO PRINTER KIOSK M/B”, “POWER BD P510K TO KIOSK SYSTEM” and “FRAME_MID_P510K” according to [Procedure No. 1, 2, 3 and 4](#).

[Step 2] Remove 2 screws and 1 connector to take out the “MTR STEP_7.5_6OHM_RBN_S_160MM ROHS”.

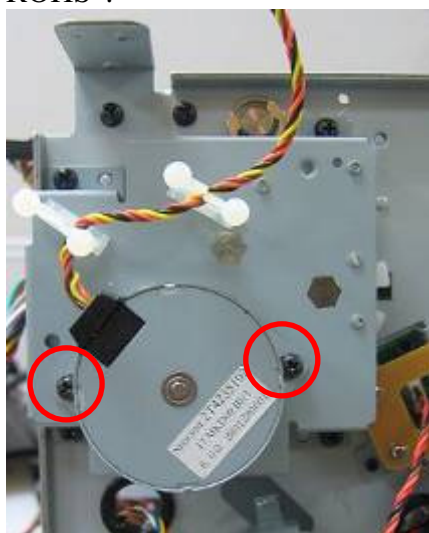
Note:

Please confirm that all the connectors are securely connected to “MAIN_BD P510K 011 ROHS” while doing assembly.

4-4-9 MTR STEP_7.5_6OHM_CAM_PLTN_200MM RED ROHS

Parts Name	MTR STEP_7.5_6OHM_CAM_PLTN_200MM RED ROHS	Part No.	17.MCD09.BM1
Tools	Phillips screwdriver (#2), screwdriver (small)	Procedure No.	9

Maintenance Parts: MTR STEP_7.5_6OHM_CAM_PLTN_200MM RED (CAM PINCH MOTOR)



[Step 1] Remove the “ID_CASE_BACK_P510K”, “ID_COVER_MB_TOP_P510K”, “ID_CASE_TOP_P510K”, “ID_CASE_TOP_FRONT_P510K”, “ASSY LCD MODULE+ID CASE TOP+DECORATION “, “ASSY_CARD_READER”, “ID_CASE_RIGHT_P510K”, “ID_DOOR_RIGHT_P510K”, “ID_CASE_LEFT_P510K”, “P510K PHOTO PRINTER KIOSK M/B”, “POWER BD P510K TO KIOSK SYSTEM” and “FRAME_MID_P510K” according to [Procedure No. 1, 2, 3 and 4](#).

[Step 2] Remove 2 screws and 1 connector to take out the “MTR STEP_7.5_6OHM_CAM_PLTN_200MM RED ROHS”.

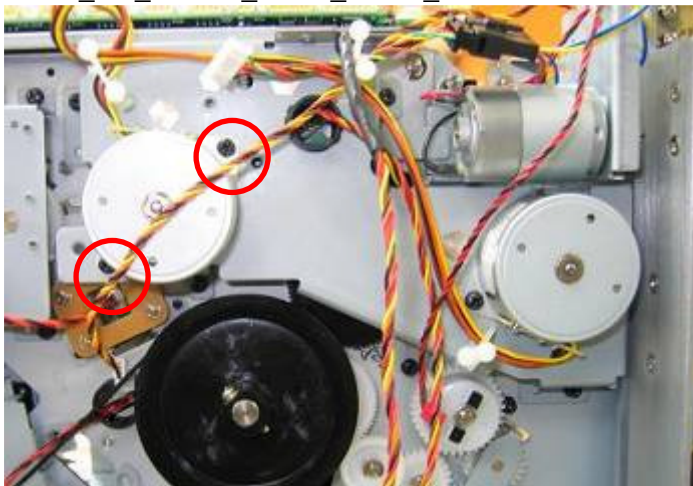

Note:

Please confirm that all the connectors are securely connected to “MAIN_BD P510K 011 ROHS” while doing assembly.

4-4-10 MTR STEP_7.5_4OHM_CAM_PINCH_90MM ROHS

Parts Name	MTR STEP_7.5_4OHM_CAM_PINCH_90MM ROHS	Part No.	17.MHD09.BM1
Tools	Phillips screwdriver (#2), screwdriver (small)	Procedure No.	10

Maintenance Parts: MTR STEP_7.5_4OHM_CAM_PINCH_90MM (CAM PLATEN ROLLER frame)



[Step 1] Remove the “ID_CASE_BACK_P510K”, “ID_COVER_MB_TOP_P510K”, “ID_CASE_TOP_P510K”, “ID_CASE_TOP_FRONT_P510K”, “ASSY LCD MODULE+ID CASE TOP+DECORATION”, “ASSY_CARD_READER”, “ID_CASE_RIGHT_P510K”, “ID_DOOR_RIGHT_P510K”, “ID_CASE_LEFT_P510K”, “P510K PHOTO PRINTER KIOSK M/B”, “POWER BD P510K TO KIOSK SYSTEM” and “FRAME_MID_P510K” according to [Procedure No. 1, 2, 3 and 4](#).

[Step 2] Remove 2 screws and 1 connector to take out the “MTR STEP_7.5_4OHM_CAM_PINCH_90MM ROHS”.

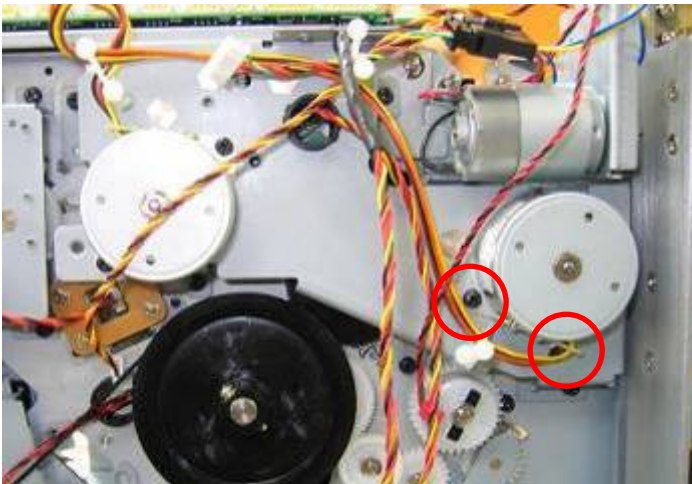

Note:

Please confirm that all the connectors are securely connected to “MAIN_BD P510K 011 ROHS” while doing assembly.

4-4-11 MTR STEP_7.5_6OHM_RBN_T_350MM ROHS

Parts Name	MTR STEP_7.5_6OHM_RBN_T_350MM ROHS	Part No.	17.MBD09.BN1
Tools	Phillips screwdriver (#2), screwdriver (small)	Procedure No.	11

Maintenance Parts: MTR STEP_7.5_6OHM_RBN_T_350MM ROHS (RIBBON TAKE MOTOR)

[Step 1] Remove the “ID_CASE_BACK_P510K”, “ID_COVER_MB_TOP_P510K”, “ID_CASE_TOP_P510K”, “ID_CASE_TOP_FRONT_P510K”, “ASSY LCD MODULE+ID CASE TOP+DECORATION”, “ASSY_CARD_READER”, “ID_CASE_RIGHT_P510K”, “ID_DOOR_RIGHT_P510K”, “ID_CASE_LEFT_P510K”, “P510K PHOTO PRINTER KIOSK M/B”, “POWER BD P510K TO KIOSK SYSTEM” and “FRAME_MID_P510K” according to [Procedure No. 1, 2, 3 and 4](#).

[Step 2] Remove 2 screws and 1 connector to take out the “MTR STEP_7.5_6OHM_RBN_T_350MM ROHS”.

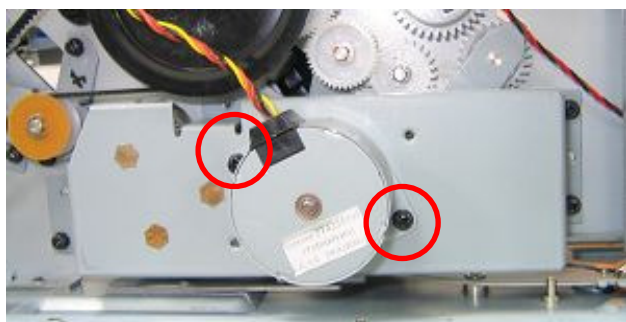
Note:

Please confirm that all the connectors are securely connected to “MAIN_BD P510K 011 ROHS” while doing assembly.

4-4-12 MTR STEP_1.8_2.4V_2.5A CAPSTON_250MM ROHS

Parts Name	MTR STEP_1.8_2.4V_2.5A CAPSTON_250MM ROHS	Part No.	17.MAD09.BT1
Tools	Phillips screwdriver (#2), screwdriver (small)	Procedure No.	12

Maintenance Parts: MTR STEP_1.8_2.4V_2.5A CAPSTON_250MM ROHS (CAPSTAN MOTOR)

[Step 1] Remove the “ID_CASE_BACK_P510K”, “ID_COVER_MB_TOP_P510K”, “ID_CASE_TOP_P510K”, “ID_CASE_TOP_FRONT_P510K”, “ASSY LCD MODULE+ID CASE TOP+DECORATION”, “ASSY_CARD_READER”, “ID_CASE_RIGHT_P510K”, “ID_DOOR_RIGHT_P510K”, “ID_CASE_LEFT_P510K”, “P510K PHOTO PRINTER KIOSK M/B”, “POWER BD P510K TO KIOSK SYSTEM” and “FRAME_MID_P510K” according to [Procedure No. 1, 2, 3 and 4](#).

[Step 2] Remove 4 screws and 1 connector to take out the “MTR STEP_1.8_2.4V_2.5A CAPSTON_250MM ROHS”.

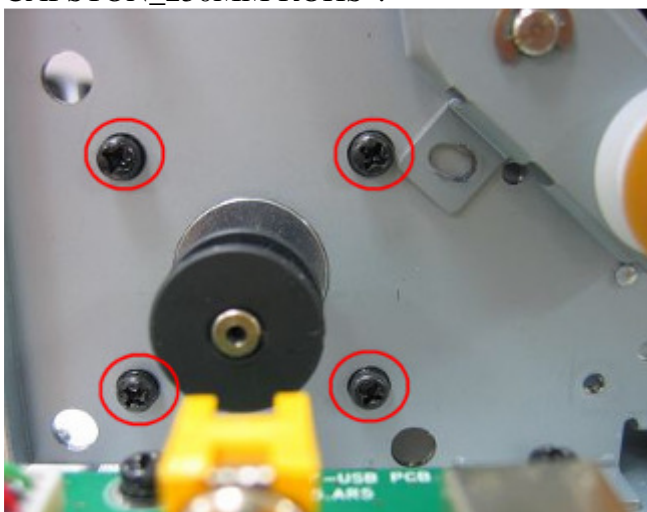
Note:

Please confirm that all the connectors are securely connected to “MAIN_BD P510K 011 ROHS” while doing assembly.

4-4-13 MTR STEP_3.75_8.5OHM_PAPER_EXIT 240MM BLUE ROHS

Parts Name	MTR STEP_3.75_8.5OHM_PAPER_EXIT 240MM BLUE ROHS	Part No.	17.MJD09.BN1
Tools	Phillips screwdriver (#2), screwdriver (small)	Procedure No.	13

Maintenance Parts: MTR STEP_3.75_8.5OHM_PAPER_EXIT 240MM BLUE ROHS (CUTTER DOOR MOTOR)



[Step 1] Remove the “ID_CASE_BACK_P510K”, “ID_COVER_MB_TOP_P510K”, “ID_CASE_TOP_P510K”, “ID_CASE_TOP_FRONT_P510K”, “ASSY LCD MODULE+ID CASE TOP+DECORATION “, “ASSY_CARD_READER”, “ID_CASE_RIGHT_P510K”, “ID_DOOR_RIGHT_P510K”, “ID_CASE_LEFT_P510K”, “P510K PHOTO PRINTER KIOSK M/B”, “POWER BD P510K TO KIOSK SYSTEM” and “FRAME_MID_P510K” according to [Procedure No. 1, 2, 3 and 4](#).

[Step 2] Remove 2 screws and 1 connector from “MAIN_BD P510K 011 ROHS” to take out the “MTR STEP_3.75_8.5OHM_PAPER_EXIT 240MM BLUE ROHS”.

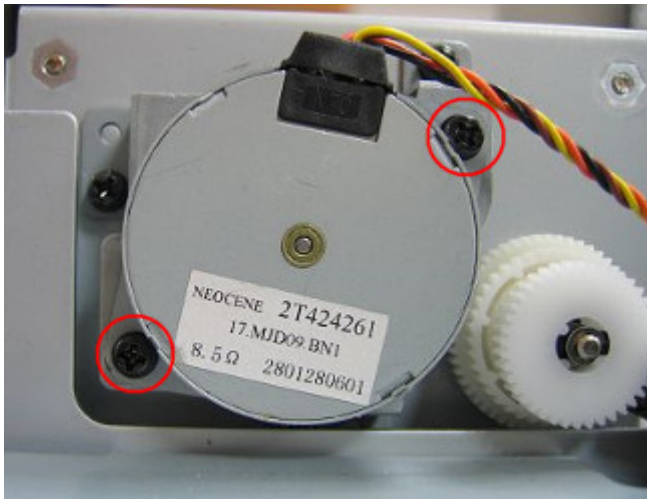

Note:

Please confirm that all the connectors are securely connected to “MAIN_BD P510K 011 ROHS” while doing assembly.

4-4-14 FRMAE_MAIN_P510K

Parts Name	FRMAE_MAIN_P510K	Part No.	
Tools	Phillips screwdriver (#2), screwdriver (small)	Procedure No.	14

Maintenance Parts:

[Step 1] Remove the “ID_CASE_BACK_P510K”, “ID_COVER_MB_TOP_P510K”, “ID_CASE_TOP_P510K”, “ID_CASE_TOP_FRONT_P510K”, “ASSY LCD MODULE+ID CASE TOP+DECORATION “, “ASSY_CARD_READER”, “ID_CASE_RIGHT_P510K”, “ID_DOOR_RIGHT_P510K”, “ID_CASE_LEFT_P510K”, “P510K PHOTO PRINTER KIOSK M/B”, “POWER BD P510K TO KIOSK SYSTEM” and “FRAME_MID_P510K” according to [Procedure No. 1, 2, 3, 4, 5 and 6](#).

[Step 2] Remove all connectors and 4 screws to take out the “FRMAE_MAIN_P510K (with MAIN_BD P510K 011 ROHS)”.

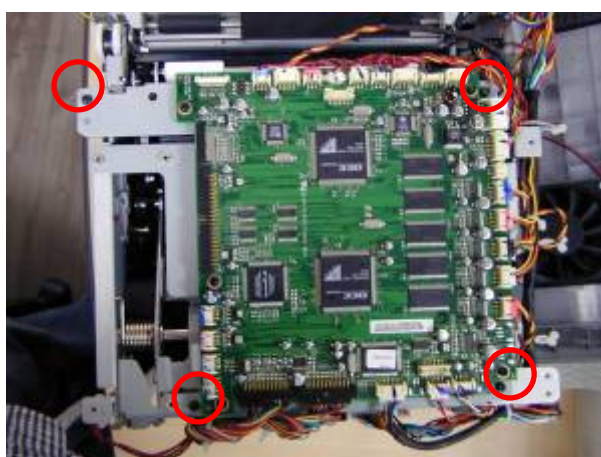

4-4-15 ROLLER_EXIT_PINCH_CUTTER_A5

Parts Name	ROLLER_EXIT_PINCH_CUTTER_A5	Part No.	59.D0909.001
Tools	Phillips screwdriver (#2), flat-blade screwdriver (small), screwdriver (small), spring hook	Procedure No.	15

Maintenance Parts: ROLLER_EXIT_PINCH_CUTTER_A5



[Step 1] Remove the “ID_CASE_BACK_P510K”, “ID_COVER_MB_TOP_P510K”, “ID_CASE_TOP_P510K”, “ID_CASE_TOP_FRONT_P510K”, “ASSY LCD MODULE+ID CASE TOP+DECORATION”, “ASSY_CARD_READER”, “ID_CASE_RIGHT_P510K”, “ID_DOOR_RIGHT_P510K”, “ID_CASE_LEFT_P510K”, “P510K PHOTO PRINTER KIOSK M/B”, “POWER BD P510K TO KIOSK SYSTEM”, “FRAME_MID_P510K” and “FRMAE_MAIN_P510K” according to [Procedure No. 1, 2, 3, 4 and 14](#).

[Step 2] Remove 2 screws and 1 E-ring then release spring from both sides.

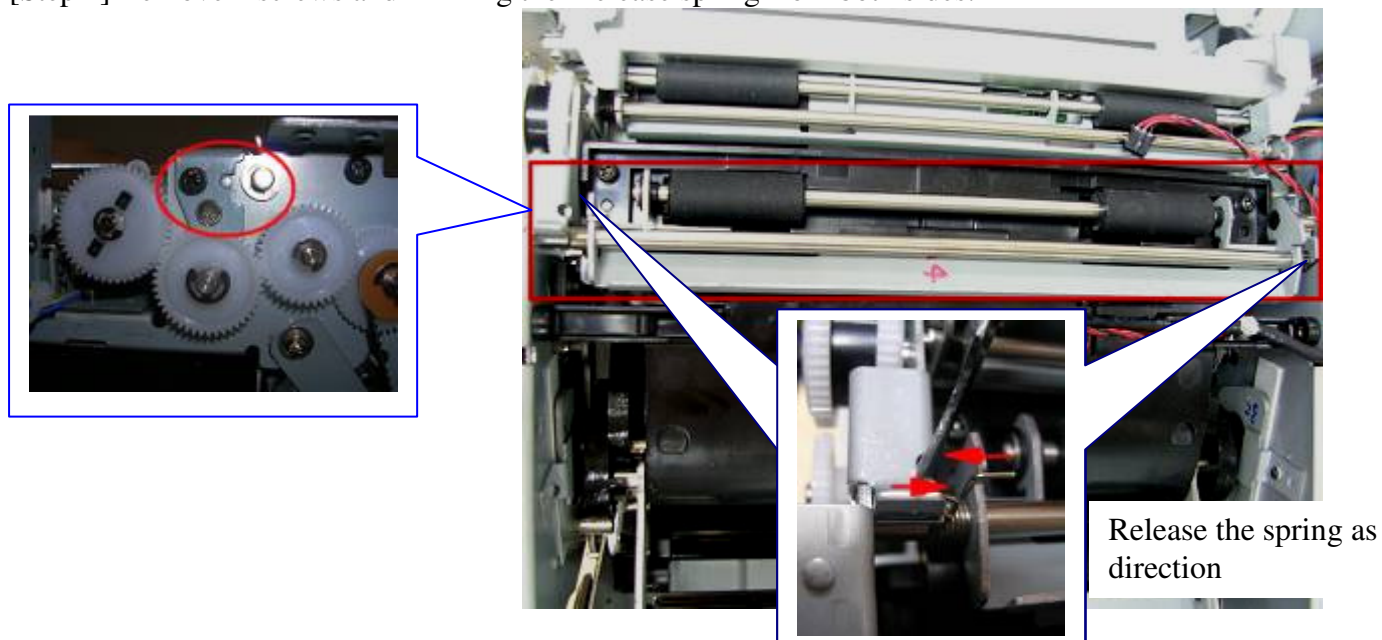

[Step 3] Pull out the “SHAFT_CUTTER” from the left side then take out the “ROLLER_EXIT_PINCH_CUTTER_A5”.

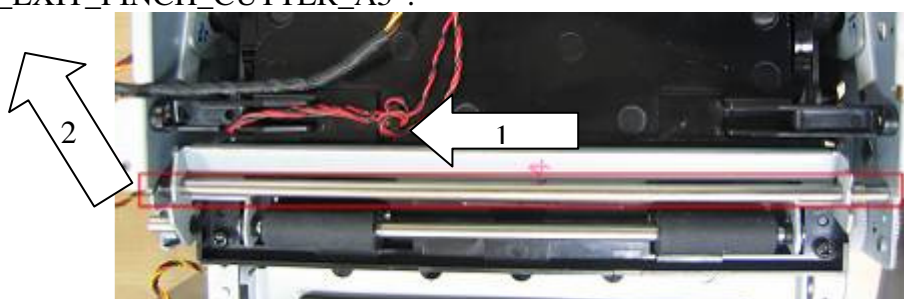



Note:

1. Watch out springs during disassembly, don't lose them.
2. Don't forget to assemble springs back, and adjust them to the correct position. Mind the spring is different on the left and right side.
3. After disassembly, please confirm there is no gap between gears; otherwise, incorrect paper cutting will be caused.



4-4-16 CUTTER_C104KZ,WIRE LE_EXIT_SNR 290MM ROHS

Parts Name	CUTTER_C104KZ WIRE LE_EXIT_SNR 290MM ROHS	Part No.	48.D0917.001 40.D0901.R01
Tools	Phillips screwdriver (#2), screwdriver (small)	Procedure No.	16

Maintenance Parts: CUTTER_C104KZ (CUTTER)



[Step 1] Remove the “ID_CASE_BACK_P510K”, “ID_COVER_MB_TOP_P510K”, “ID_CASE_TOP_P510K”, “ID_CASE_TOP_FRONT_P510K”, “ASSY LCD MODULE+ID CASE TOP+DECORATION “, “ASSY_CARD_READER”, “ID_CASE_RIGHT_P510K”, “ID_DOOR_RIGHT_P510K”, “ID_CASE_LEFT_P510K”, “P510K PHOTO PRINTER KIOSK M/B”, “POWER BD P510K TO KIOSK SYSTEM”, “FRAME_MID_P510K” and “FRMAE_MAIN_P510K“ according to [Procedure No. 1, 2, 3, 4 and 14](#).

[Step 2] Remove 2 screws then take out the small metal plate.



[Step 3] Remove 2 screws (from both sides) and 2 connectors to take out the “CUTTER_C104KZ”.

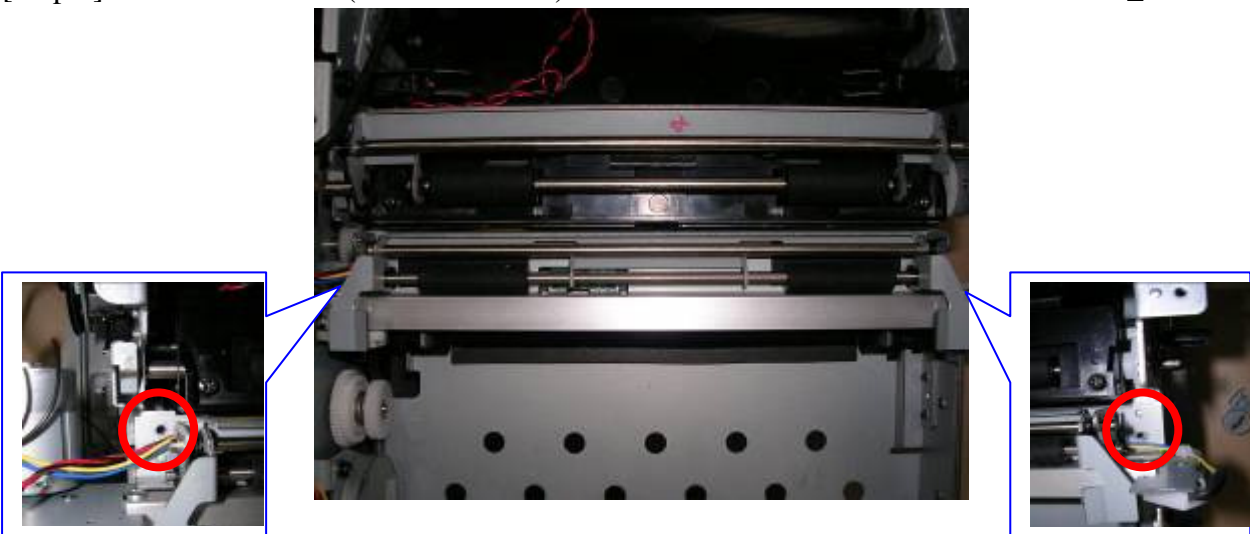

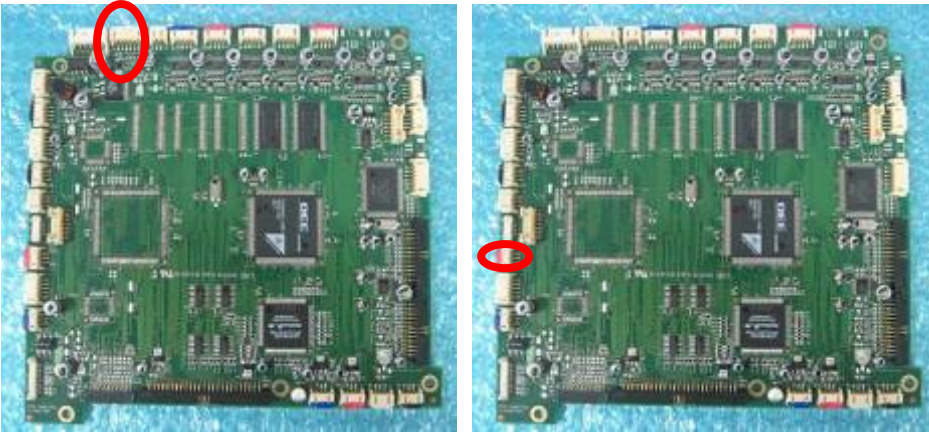

Note:

1. After disassembly, please confirm there is no gap between gears; otherwise, incorrect paper cutting will be caused.

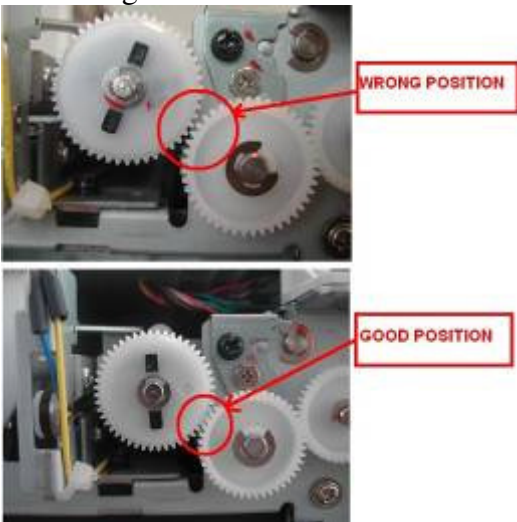

2. Remove 3 screws to take out the “CUTTER_C104KZ1”. Remove 2 screws to take out the “WIRE LE_EXIT_SNR 290MM ROHS”.

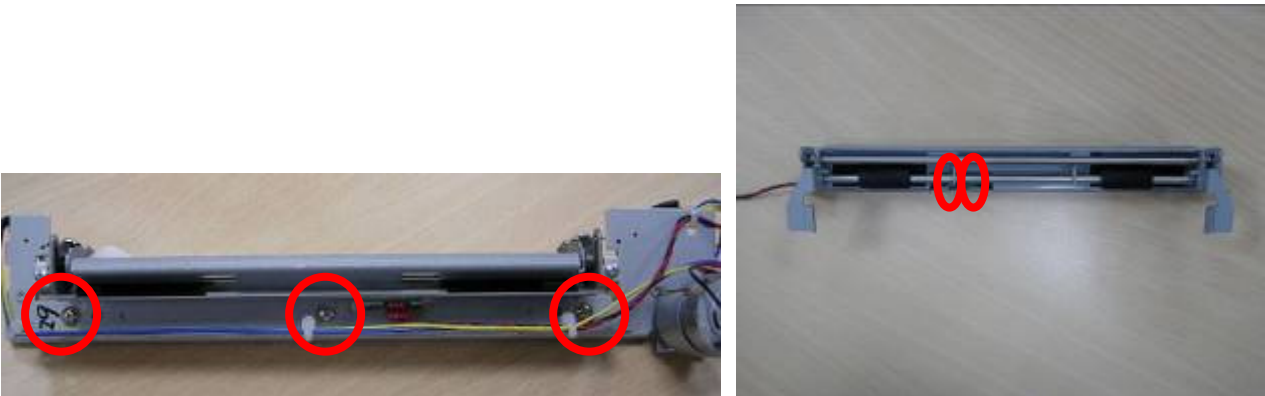

4-4-17 LINKAGE_MODULE_P510S

Parts Name	LINKAGE_MODULE_P510S	Part No.	47.D0928.001
Tools	Phillips screwdriver (#2), screwdriver (small), flat-blade screwdriver (small), pliers	Procedure No.	17

Maintenance Parts: LINKAGE_MODULE_P510S (TPH LINKAGE)

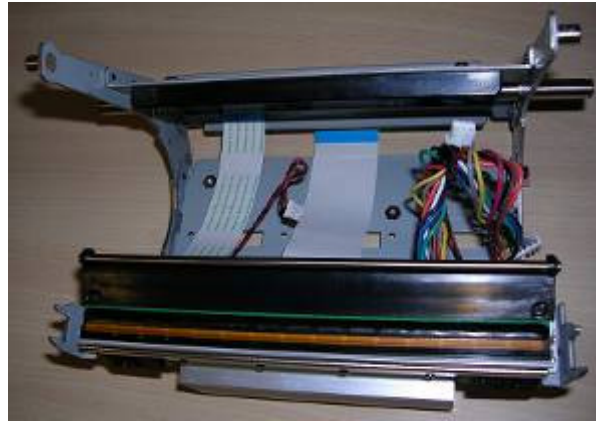
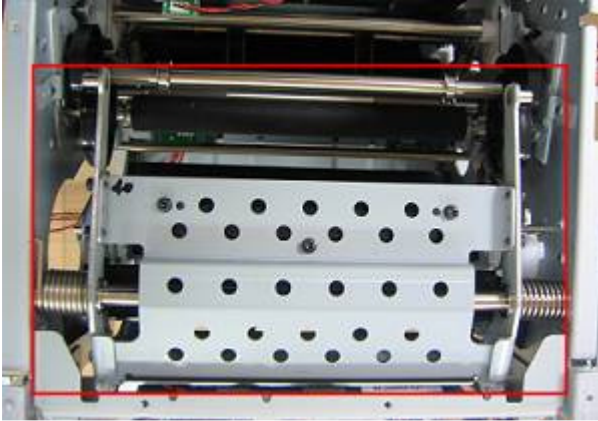

[Step 1] Remove the “ID_CASE_BACK_P510K”, “ID_COVER_MB_TOP_P510K”, “ID_CASE_TOP_P510K”, “ID_CASE_TOP_FRONT_P510K”, “ASSY LCD MODULE+ID CASE TOP+DECORATION “, “ASSY_CARD_READER”, “ID_CASE_RIGHT_P510K”, “ID_DOOR_RIGHT_P510K”, “ID_CASE_LEFT_P510K”, “P510K PHOTO PRINTER KIOSK M/B”, “POWER BD P510K TO KIOSK SYSTEM”, “FRAME_MID_P510K” “FRMAE_MAIN_P510K“ and “ROLLER_EXIT_PINCH_CUTTER_A5 according to [Procedure No. 1, 2, 3, 4, 14 and 15](#).

[Step 2] Remove 4 screws to take out the “FRAME_RBN_SUPPLY_P510S”.



[Step 3] Remove 6 screws and 2 E-rings to take out the “FRAME_TPH”.

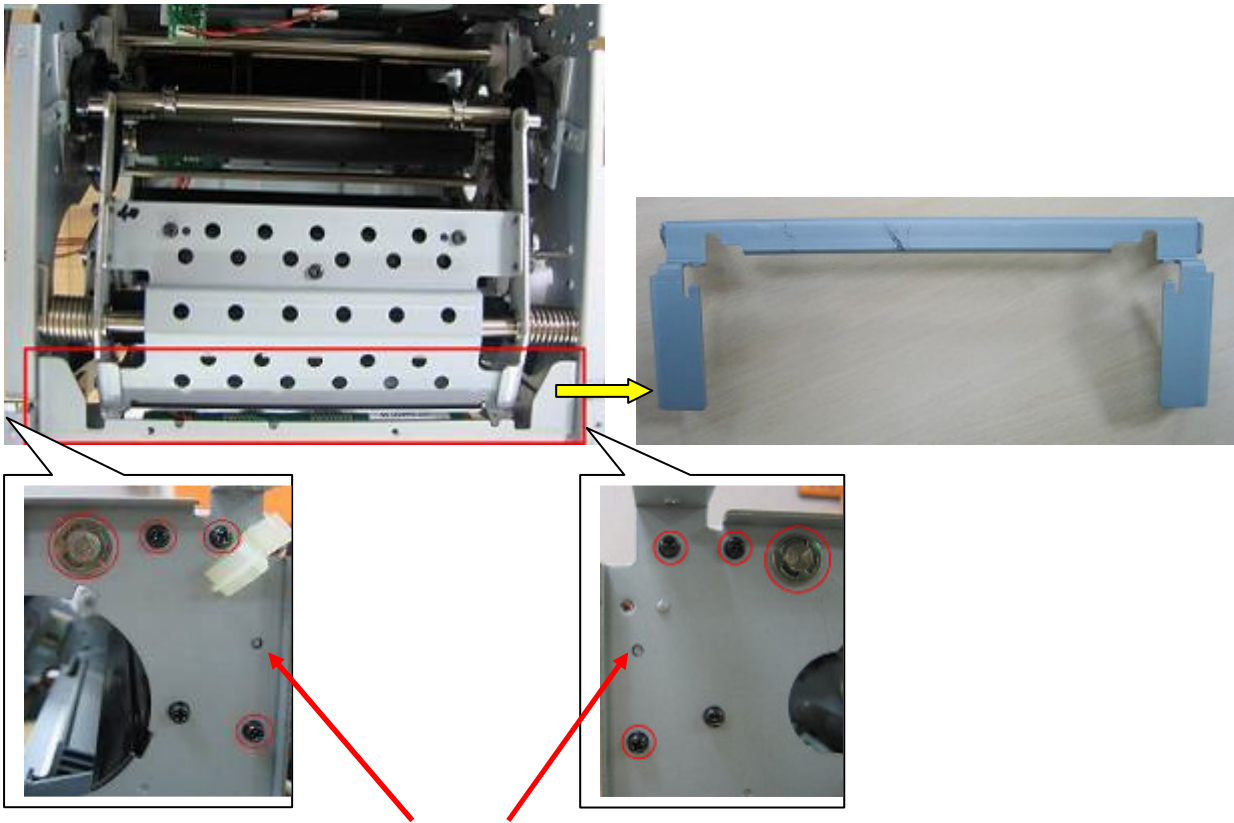

[Step 4] Release spring from the right side. Shift the “LINKAGE_MODULE_P510S” to the left side then move it up and out from the top and back sides.

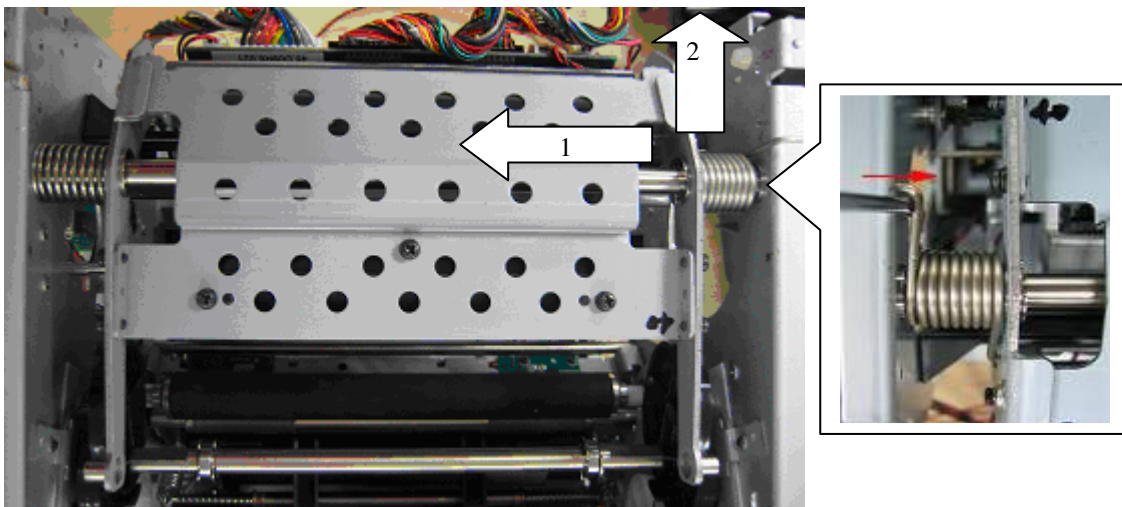

Note:

1. Mind the installation of bearings on the both sides. Don't scratch or deform them or they will become hard to install.

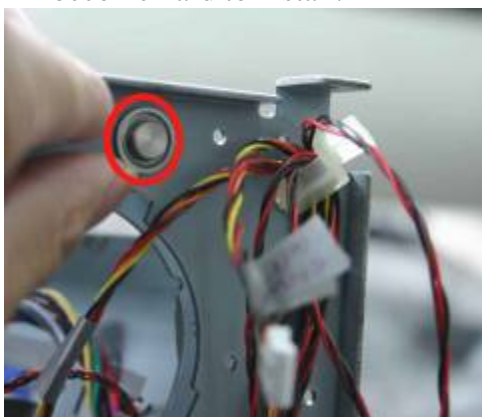

2. Mind the position of springs and tube.

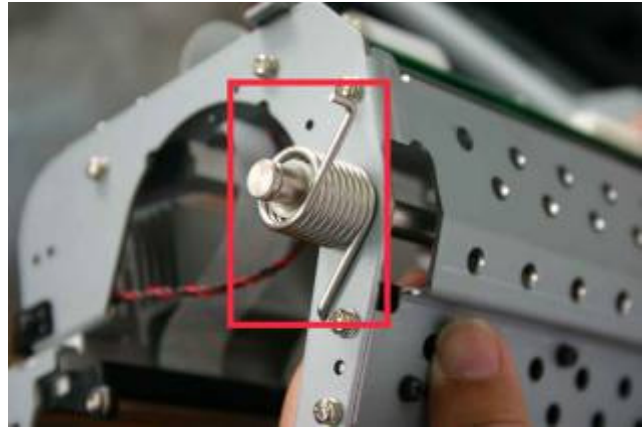

4-4-18 TRAY_EXIT_ASSY

Parts Name	TRAY_EXIT_ASSY	Part No.	48.D0911.001
Tools	Phillips screwdriver (#2), screwdriver (small)	Procedure No.	18

Maintenance Parts: TRAY_EXIT

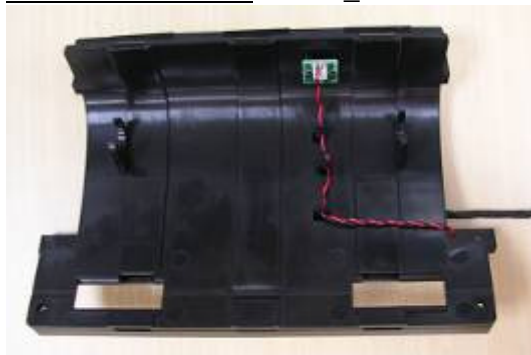

[Step 1] Remove the “ID_CASE_BACK_P510K”, “ID_COVER_MB_TOP_P510K”, “ID_CASE_TOP_P510K”, “ID_CASE_TOP_FRONT_P510K”, “ASSY LCD MODULE+ID CASE TOP+DECORATION “, “ASSY_CARD_READER”, “ID_CASE_RIGHT_P510K”, “ID_DOOR_RIGHT_P510K”, “ID_CASE_LEFT_P510K”, “P510K PHOTO PRINTER KIOSK M/B”, “POWER BD P510K TO KIOSK SYSTEM”, “FRAME_MID_P510K”, “FRMAE_MAIN_P510K”, “ROLLER_EXIT_PINCH_CUTTER_A5” and “LINKAGE_MODULE_P510S” according to [Procedure No. 1, 2, 3, 4, 14, 15 and 17.](#)

[Step 2] Remove screws from the both sides.

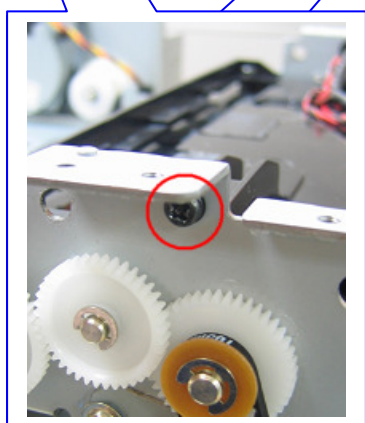
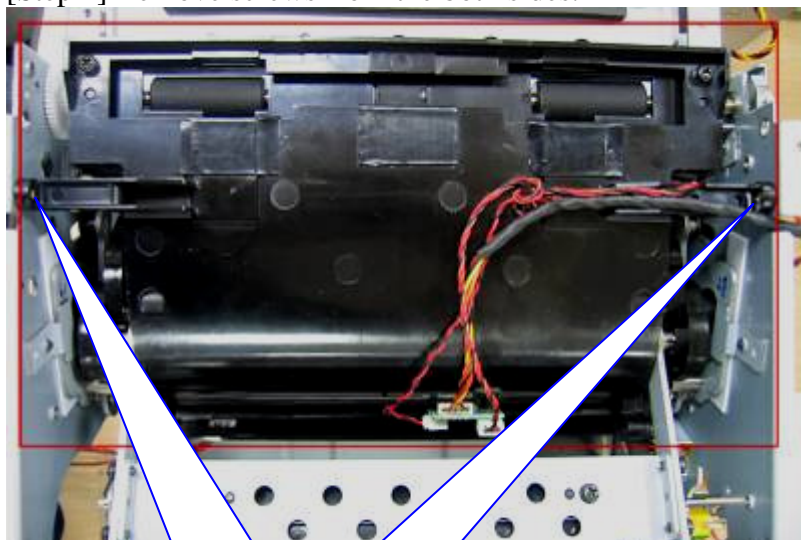

[Step 3] Remove 1 connector.



[Step 4] Pull up the “TRAY_EXIT_ASSY” from the “SHAFT_CAM_PLATEN”.

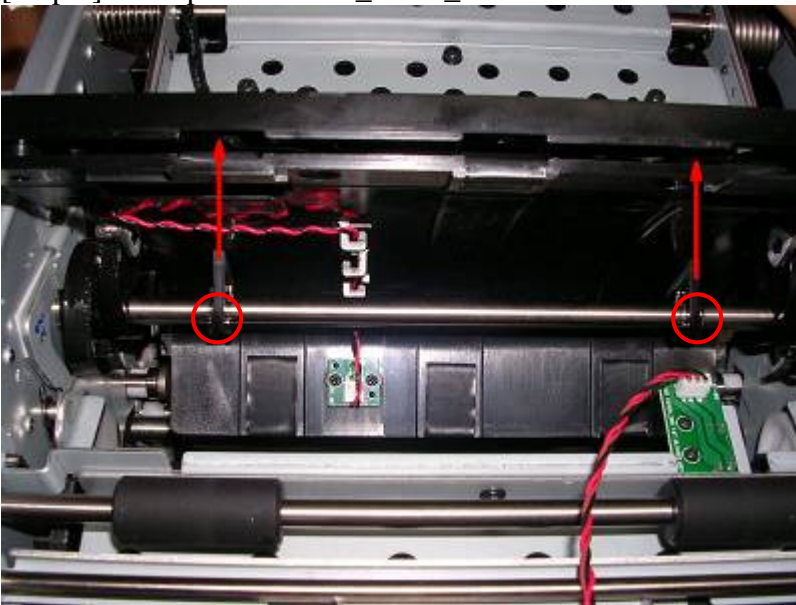

SHAFT_CAM_PLATEN

4-4-19 SUB_TPH_ASSY

Parts Name	SUB_TPH_ASSY	Part No.	47.D0924.001
Tools	Phillips screwdriver (#2), screwdriver (small)	Procedure No.	19

Maintenance Parts: SUB_TPH_ASSY (TPH)



[Step 1] Remove the “ID_CASE_BACK_P510K” according to **Procedure No. 1 step 1**.

[Step 2] Remove 2 screws, 2 flat cables (FLAT CABLE 20P P1.0 110MM DP ROHS) and 1 wire connector then take “SUB_TPH_ASSY” out from the entrance of ribbon cartridge.

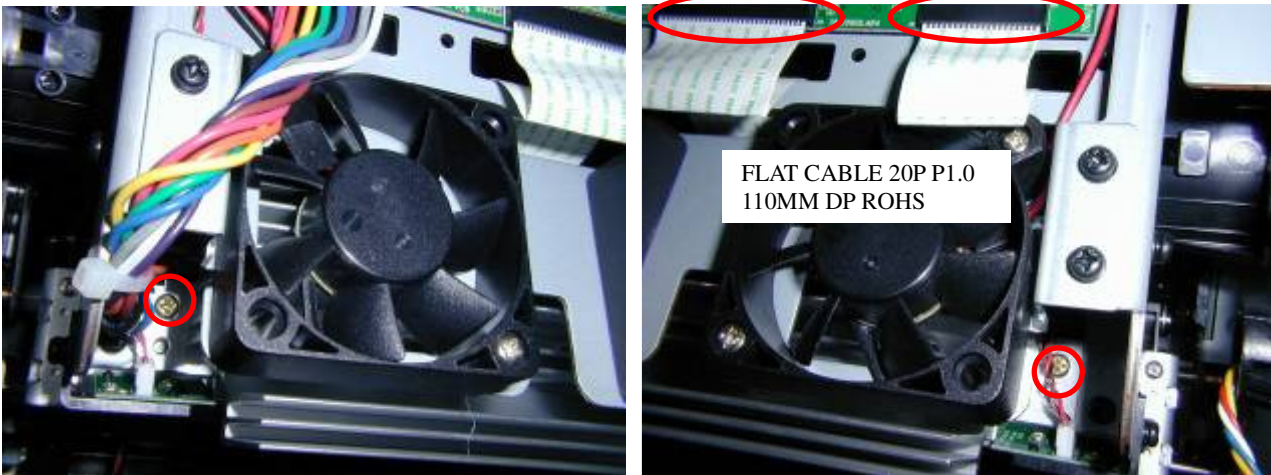
Note:

1. After disassembly, please confirm “FLAT CABLE 20P P1.0 110MM DP ROHS” are securely connected on the TPH and TPH board sides.
2. Before changing the “SUB_TPH_ASSY”, put silicone heat sink compound on the back side of new “SUB_TPH_ASSY” so it will be helpful to the heat conduction.

Please make sure two flat cables will be curved naturally to avoid chart abnormal issue.

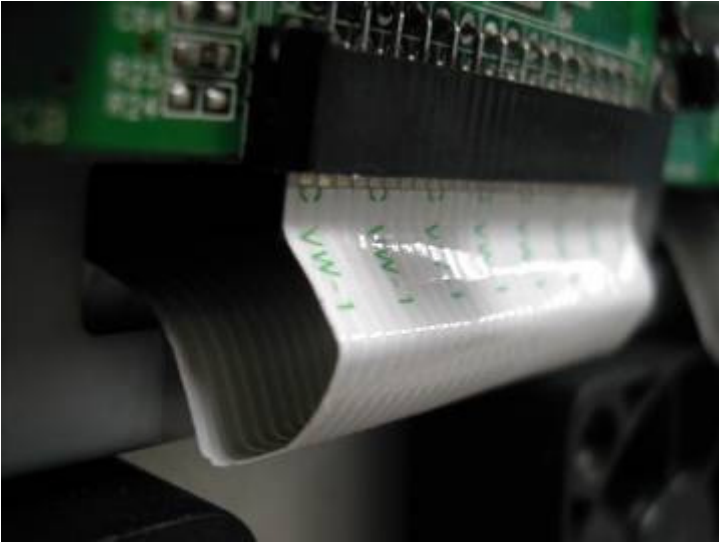

Please make sure cable path is correct to avoid cam platen error issue

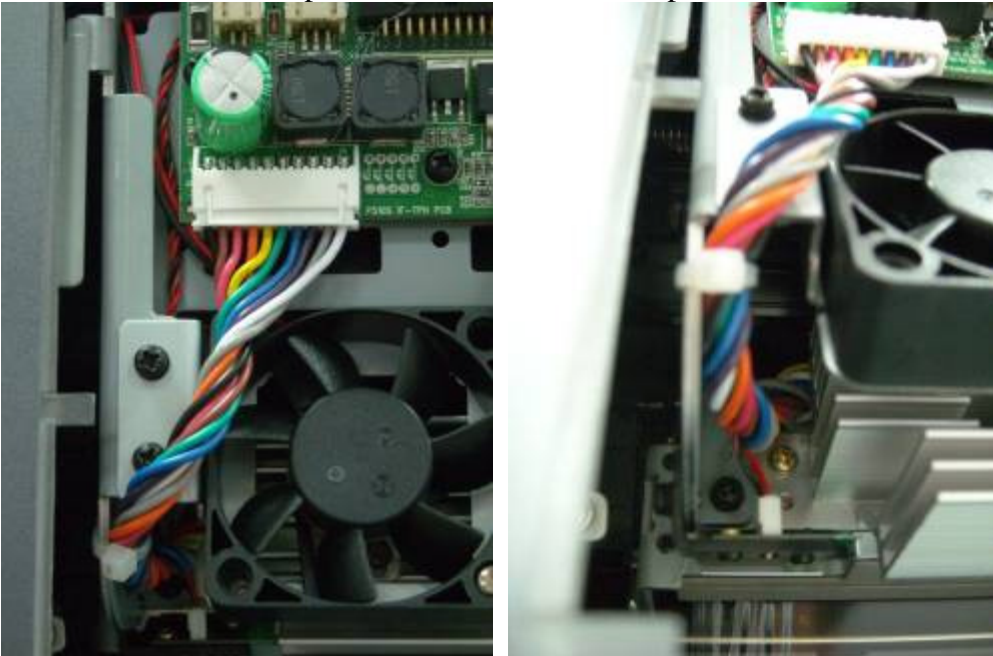

4-4-20 CAPSTAN_ROLLER_A5

Parts Name	CAPSTAN_ROLLER_A5	Part No.	53.D0911.001
Tools	Phillips screwdriver (#2), screwdriver (small), flat-blade screwdriver (small)	Procedure No.	20

Maintenance Parts: CAPSTAN_ROLLER_A5 (CAPSTAN ROLLER)

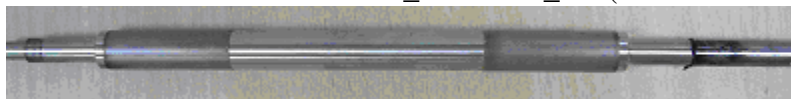

[Step 1] Remove the “ID_CASE_BACK_P510K”, “ID_COVER_MB_TOP_P510K”, “ID_CASE_TOP_P510K”, “ID_CASE_TOP_FRONT_P510K”, “ASSY LCD MODULE+ID CASE TOP+DECORATION “, “ASSY_CARD_READER”, “ID_CASE_RIGHT_P510K”, “ID_DOOR_RIGHT_P510K”, “ID_CASE_LEFT_P510K”, “P510K PHOTO PRINTER KIOSK M/B”, “POWER BD P510K TO KIOSK SYSTEM”, “FRAME_MID_P510K”, “FRMAE_MAIN_P510K”, “ROLLER_EXIT_PINCH_CUTTER_A5”, “LINKAGE_MODULE_P510S” and “TRAY_EXIT_ASSY “ according to [Procedure No. 1, 2, 3, 4, 14, 15, 17 and 18.](#)

[Step 2] Remove E-ring , pad, belt, gear and bearing from the right side.

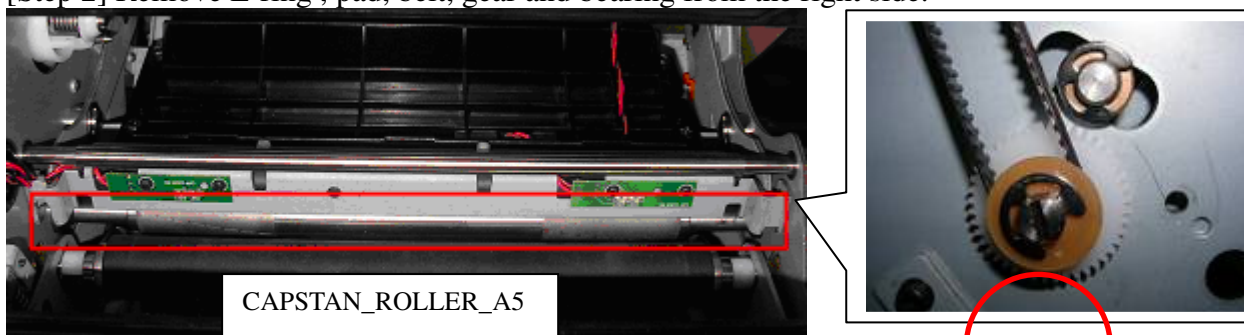

[Step 3] Remove 4 screws from the left side then release the belt.



[Step 4] Remove 1 screw to take out the “GEAR_CAPSTAN” and belt. Mind the spring and gasket which are under the “GEAR_CAPSTAN”.

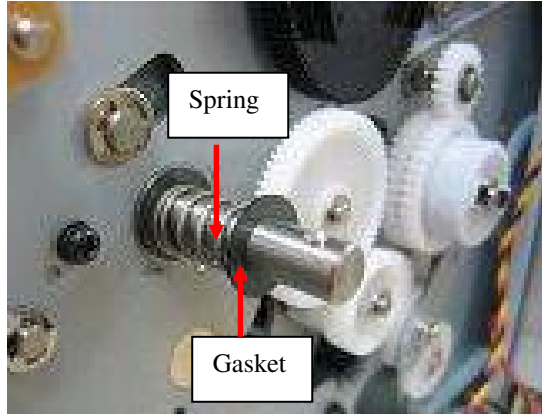
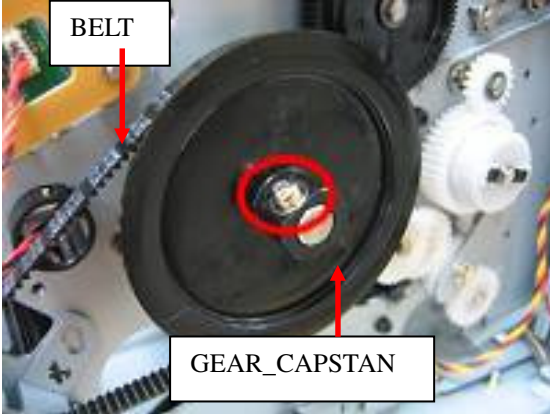

[Step 5] Slide the “CAPSTAN_ROLLER_A5” to the left side then take it out.

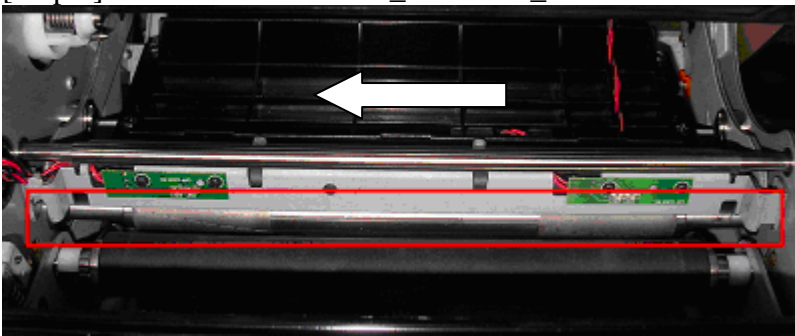

Note:

Mind the size of bearing at the right and left sides are different.



Left side = Bigger

Right side= Smaller

4-4-21 ROLLER_PLATEN_NEW_A5

Parts Name	ROLLER_PLATEN_NEW_A5	Part No.	59.D0906.001
Tools	Phillips screwdriver (#2), screwdriver (small), flat-blade screwdriver (small)	Procedure No.	21

Maintenance Parts: ROLLER_PLATEN_NEW_A5 (PLATEN ROLLER)



[Step 1] Remove the “ID_CASE_BACK_P510K”, “ID_COVER_MB_TOP_P510K”, “ID_CASE_TOP_P510K”, “ID_CASE_TOP_FRONT_P510K”, “ASSY LCD MODULE+ID CASE TOP+DECORATION”, “ASSY_CARD_READER”, “ID_CASE_RIGHT_P510K”, “ID_DOOR_RIGHT_P510K”, “ID_CASE_LEFT_P510K”, “P510K PHOTO PRINTER KIOSK M/B”, “POWER BD P510K TO KIOSK SYSTEM”, “FRAME_MID_P510K”, “FRMAE_MAIN_P510K”, “ROLLER_EXIT_PINCH_CUTTER_A5”, “LINKAGE_MODULE_P510S” and “TRAY_EXIT_ASSY” according to [Procedure No. 1, 2, 3, 4, 14, 15, 17 and 18](#).

[Step 2] Remove 2 E-rings and oil-retaining bearings from the both sides.

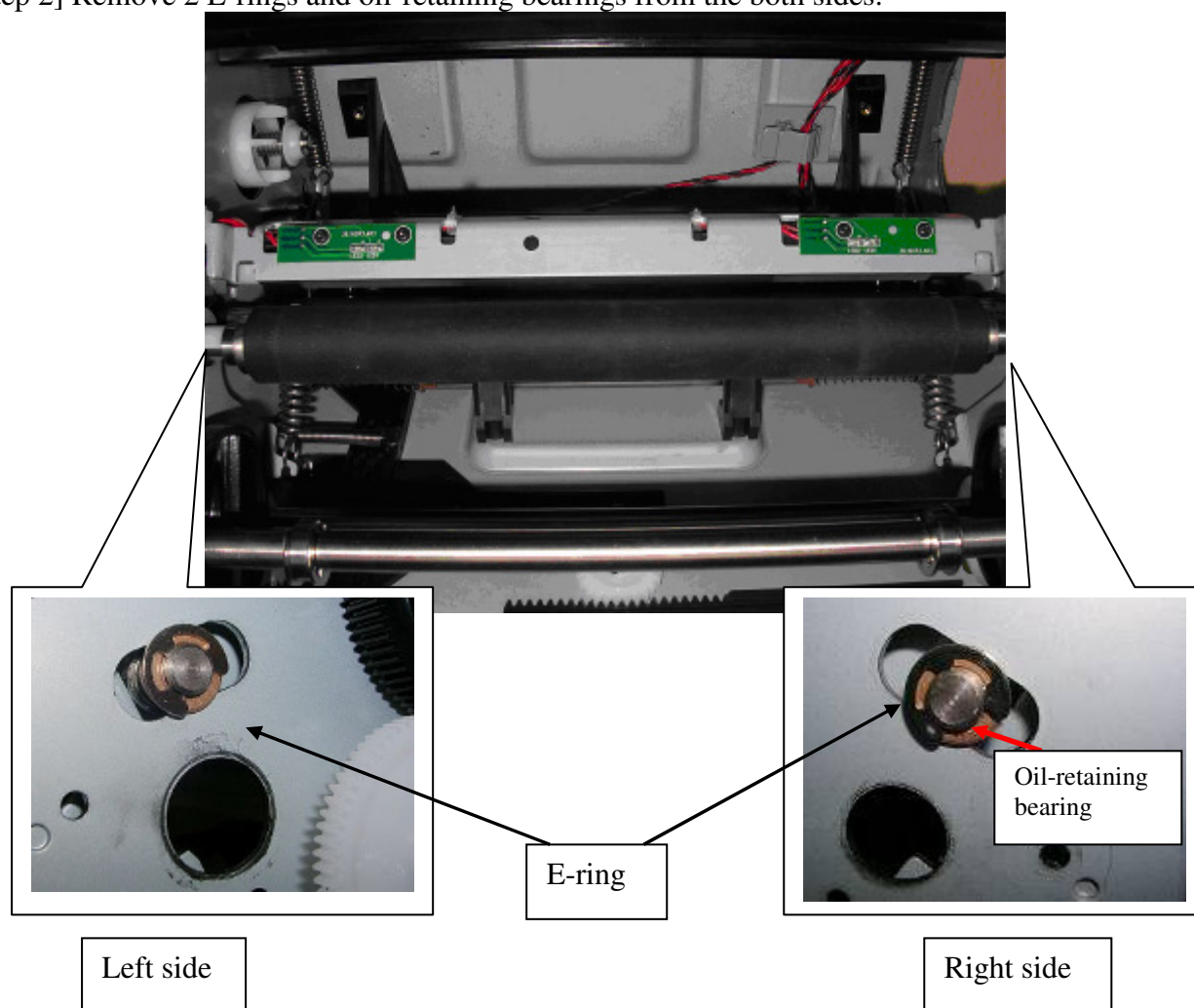

[Step 3] Remove 2 clamps from the both sides. Shift the “ROLLER_PLATEN_NEW_A5” to the left side then move it out from the back side. Remove the oil-retaining bearing together. (The oil-retaining bearing is used to install the platen roller.)

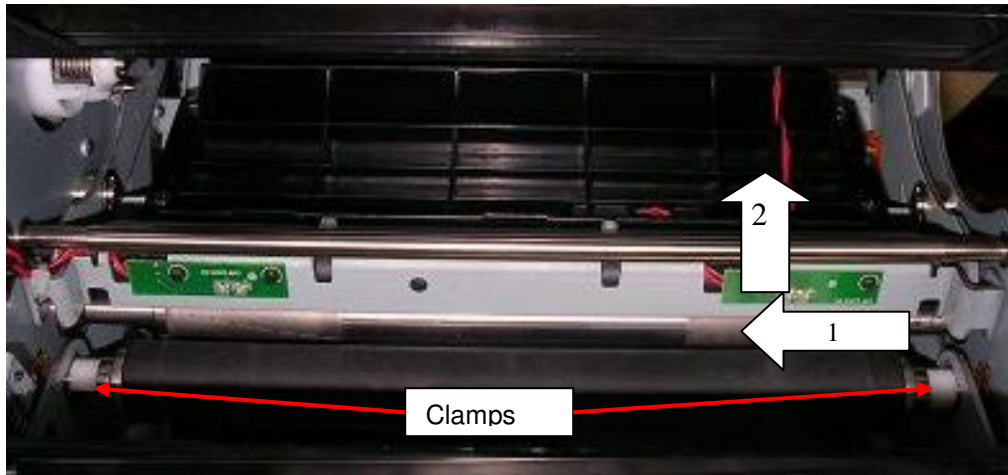

Note:

Mind the location of the bearing, washer and oil-retaining bearing.



4-4-22 ROLLER_PINCH_A5

Parts Name	ROLLER_PINCH_A5	Part No.	59.D0905.001
Tools	Phillips screwdriver (#2), screwdriver (small), Flat-blade screwdriver (small)	Procedure No.	22

Maintenance Parts: ROLLER_PINCH_A5 (PINCH ROLLER)



[Step 1] Remove the “ID_CASE_BACK_P510K”, “ID_COVER_MB_TOP_P510K”, “ID_CASE_TOP_P510K”, “ID_CASE_TOP_FRONT_P510K”, “ASSY LCD MODULE+ID CASE TOP+DECORATION “, “ASSY_CARD_READER”, “ID_CASE_RIGHT_P510K”, “ID_DOOR_RIGHT_P510K”, “ID_CASE_LEFT_P510K”, “P510K PHOTO PRINTER KIOSK M/B”, “POWER BD P510K TO KIOSK SYSTEM”, “FRAME_MID_P510K”, “FRMAE_MAIN_P510K”, “ROLLER_EXIT_PINCH_CUTTER_A5”, “LINKAGE_MODULE_P510S”, “TRAY_EXIT_ASSY “ and “CAPSTAN_ROLLER_A5” according to [Procedure No. 1, 2, 3, 4, 14, 15, 17, 18 and 20](#).

[Step 2] Remove 1 E-ring from the left side then pull the “SHAFT_PEELER_BAR” out from the left side.

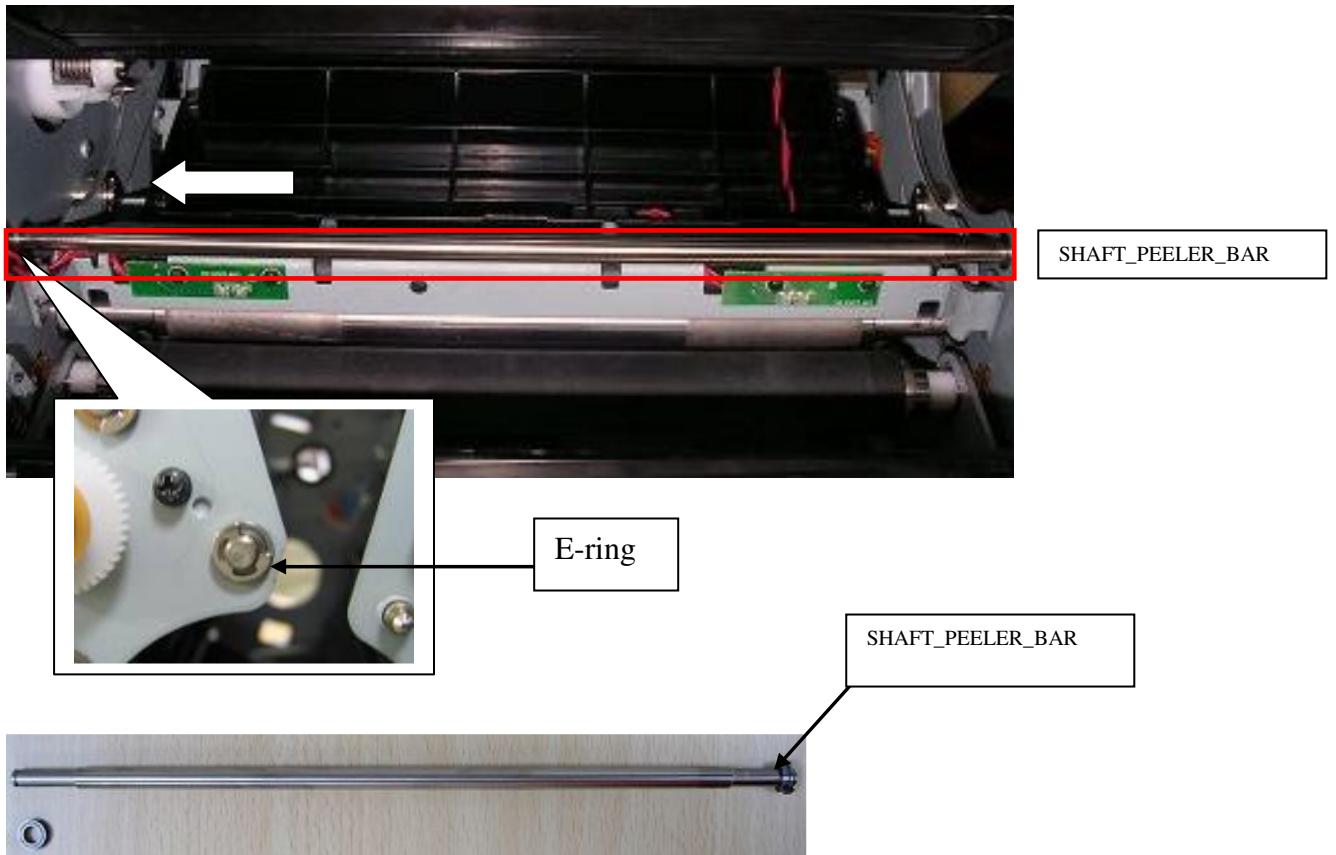

[Step 3] Remove 2 screws from the both sides of “HOLDER_SENSOR_RBN_LEFT” and 2 connectors then take “HOLDER_SENSOR_RBN_LEFT” out from the back side.

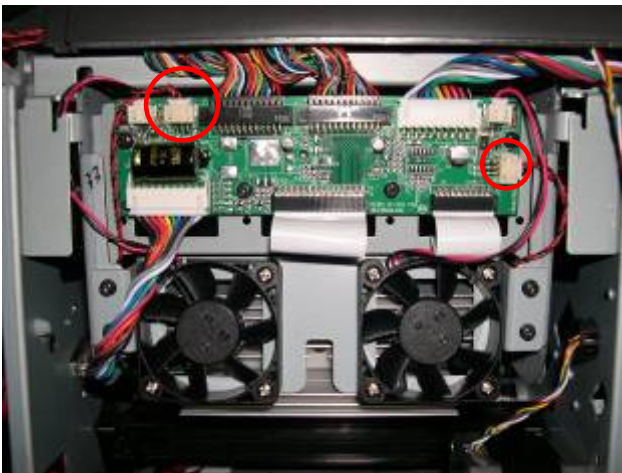
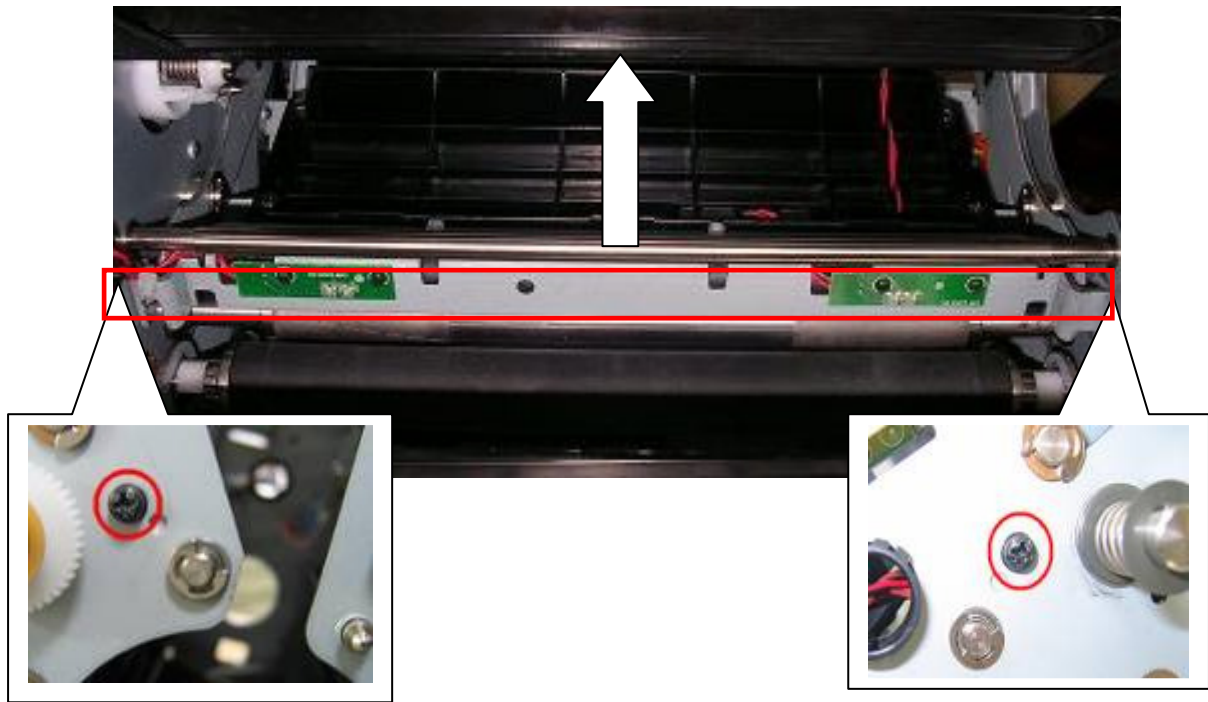

[Step 3] Remove 2 clamps from the both sides the shift “ROLLER_PINCH_A5” to the right side, and then pull it out from the back side.

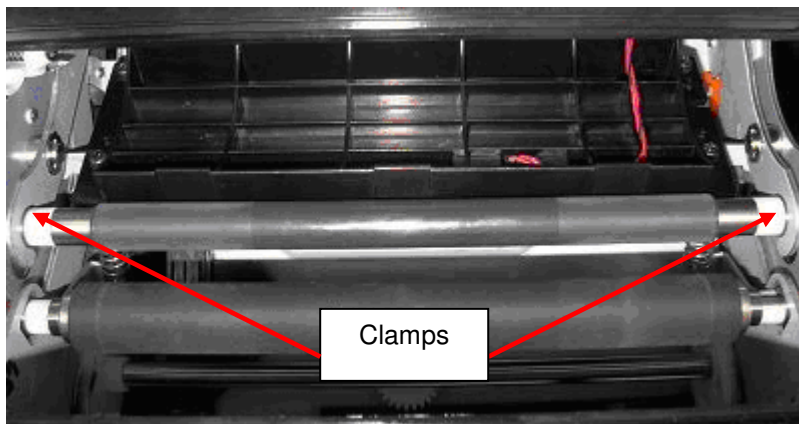

Note:

Mind the oil-retaining bearings may fall down from both sides when you take out the “ROLLER_PINCH_A5”. Remove them sequently and carefully.

4-4-23 TRAY_FEED

Parts Name	TRAY_FEED	Part No.	48.D0910.001
Tools	Phillips screwdriver (#2), screwdriver (small)	Procedure No.	23

Maintenance Parts: TRAY_FEED (TRAY FEED)



[Step 1] Remove the “ID_CASE_BACK_P510K”, “ID_COVER_MB_TOP_P510K”, “ID_CASE_TOP_P510K”, “ID_CASE_TOP_FRONT_P510K”, “ASSY LCD MODULE+ID CASE TOP+DECORATION “, “ASSY_CARD_READER”, “ID_CASE_RIGHT_P510K”, “ID_DOOR_RIGHT_P510K”, “ID_CASE_LEFT_P510K”, “P510K PHOTO PRINTER KIOSK M/B”, “POWER BD P510K TO KIOSK SYSTEM”, “FRAME_MID_P510K”, “FRMAE_MAIN_P510K”, “ROLLER_EXIT_PINCH_CUTTER_A5”, “LINKAGE_MODULE_P510S”, “TRAY_EXIT_ASSY “, “CAPSTAN_ROLLER_A5”, “ROLLER_PLATEN_NEW_A5” and “ROLLER_PINCH_A5” according to [Procedure No. 1, 2, 3, 4, 14, 15, 17, 18, 20, 21 and 22](#).

[Step 2] Remove 4 screws that hold the “TRAY_FEED” then take it out.

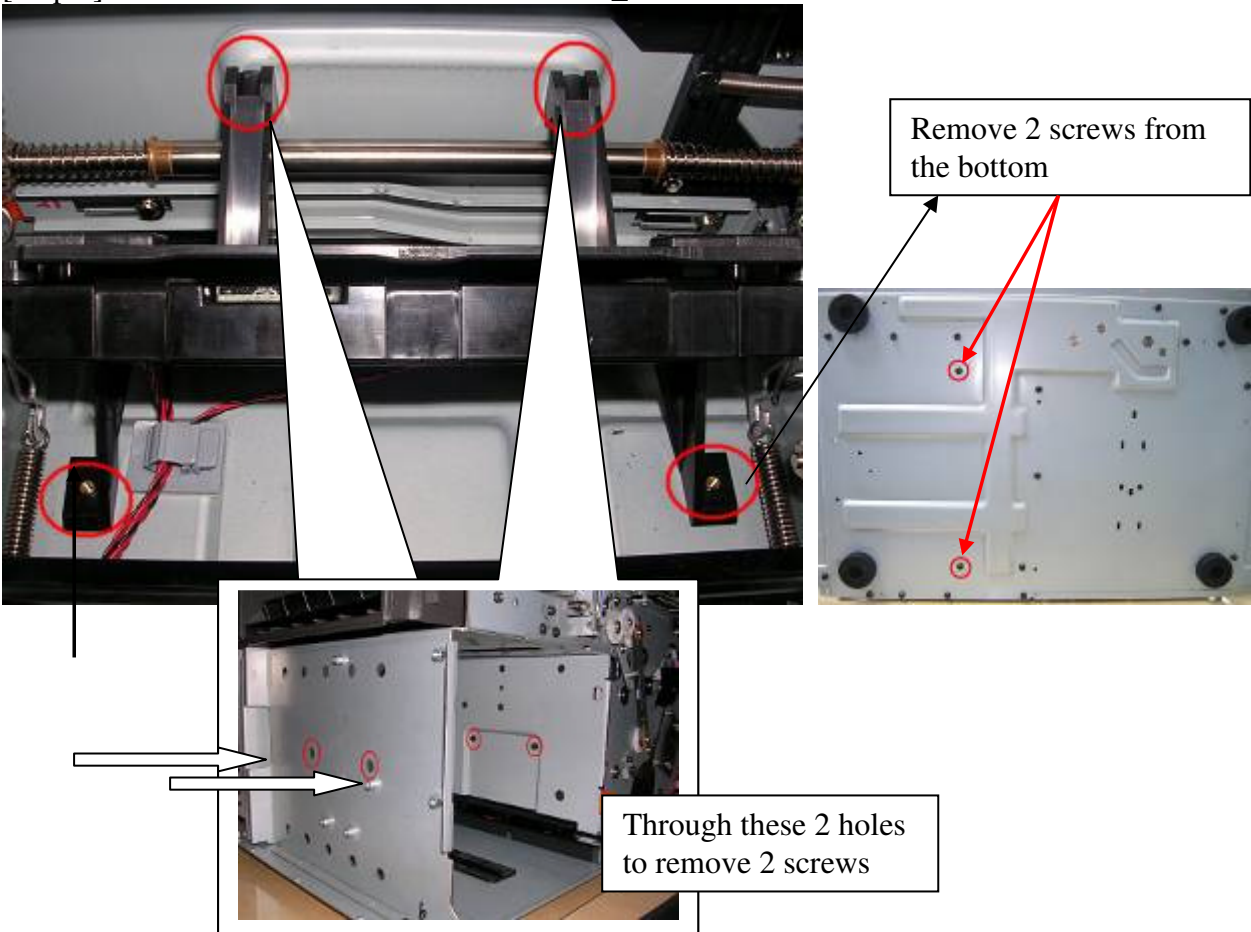

4-4-24 WIRE DOOR_SNR 310MM ROHS

Parts Name	WIRE DOOR_SNR 310MM ROHS	Part No.	40.D0909.R01
Tools	Phillips screwdriver (#2), screwdriver (small)	Procedure No.	24

Maintenance Parts: WIRE DOOR_SNR 310MM ROHS (DOOR SENSOR)

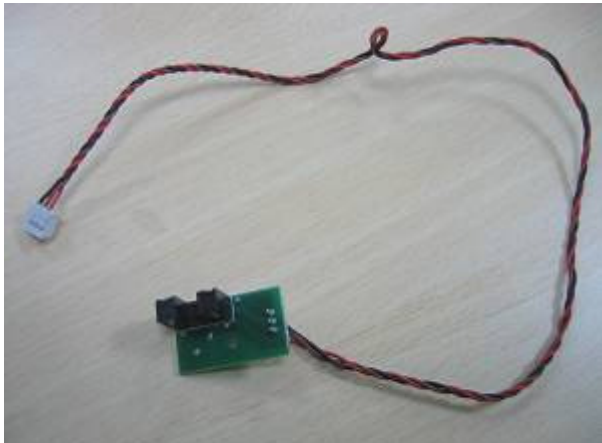

[Step 1] Remove the “ID_CASE_BACK_P510K”, “ID_COVER_MB_TOP_P510K”, “ID_CASE_TOP_P510K”, “ID_CASE_TOP_FRONT_P510K”, “ASSY LCD MODULE+ID CASE TOP+DECORATION”, “ASSY_CARD_READER”, “ID_CASE_RIGHT_P510K”, “ID_DOOR_RIGHT_P510K”, “ID_CASE_LEFT_P510K”, “P510K PHOTO PRINTER KIOSK M/B”, “POWER BD P510K TO KIOSK SYSTEM”, “FRAME_MID_P510K”, “FRMAE_MAIN_P510K”, “ROLLER_EXIT_PINCH_CUTTER_A5”, “LINKAGE_MODULE_P510S” and “TRAY_EXIT_ASSY” according to [Procedure No. 1, 2, 3, 4, 14, 15, 17 and 18](#).

[Step 2] Remove 2 screws and 1 connector to take out the “WIRE DOOR_SNR 310MM ROHS”.

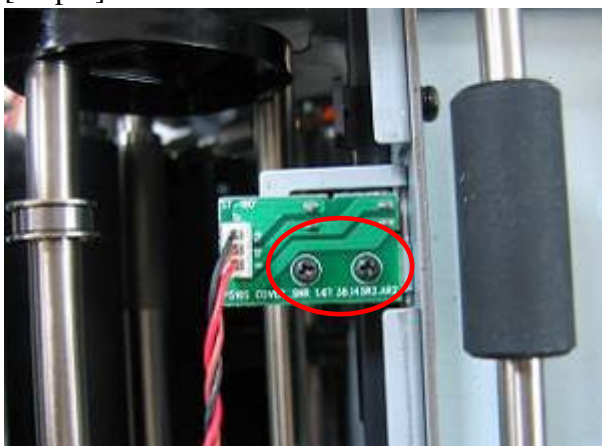
Note:

Please confirm that the connector is securely connected to “MAIN_BD P510K 011 ROHS” while doing assembly.

4-4-25 WIRE PAPER_BOX_SNR 390MM BLUE ROHS

Parts Name	WIRE PAPER_BOX_SNR 390MM BLUE ROHS	Part No.	40.D0903.R01
Tools	Phillips screwdriver (#2), screwdriver (small)	Procedure No.	25

Maintenance Parts: WIRE PAPER_BOX_SNR 390MM BLUE ROHS (PAPER BOX SENSOR)



[Step 1] Remove the “ID_CASE_BACK_P510K”, “ID_COVER_MB_TOP_P510K”, “ID_CASE_TOP_P510K”, “ID_CASE_TOP_FRONT_P510K”, “ASSY LCD MODULE+ID CASE TOP+DECORATION “, “ASSY_CARD_READER”, “ID_CASE_RIGHT_P510K”, “ID_DOOR_RIGHT_P510K”, “ID_CASE_LEFT_P510K” and “POWER BD P510 002 ROHS“ according to [Procedure No. 1 and 6](#).

[Step 2] Remove 4 screws..

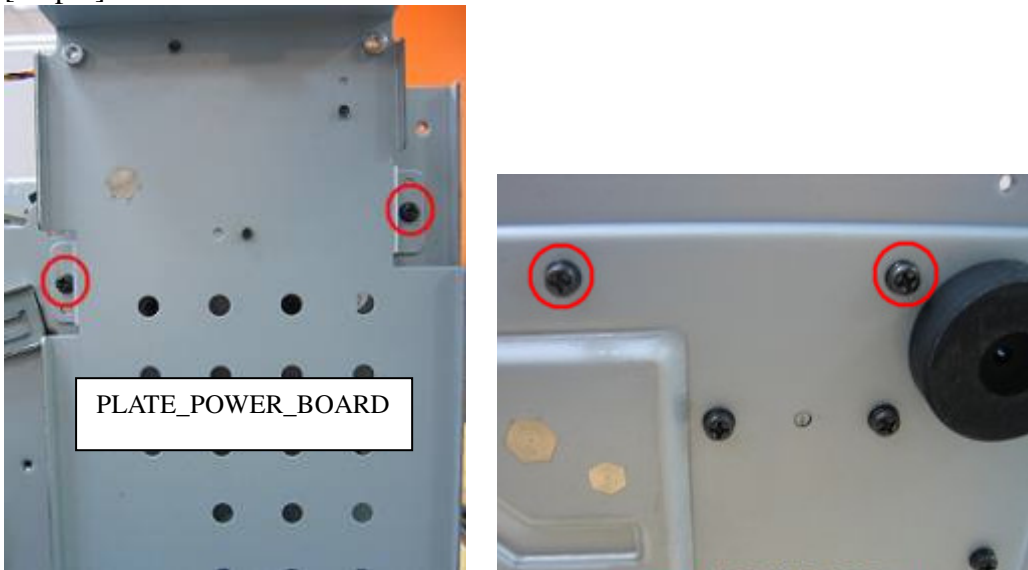

[Step 3] Release spring then take out the “PLATE_POWER_BOARD”.

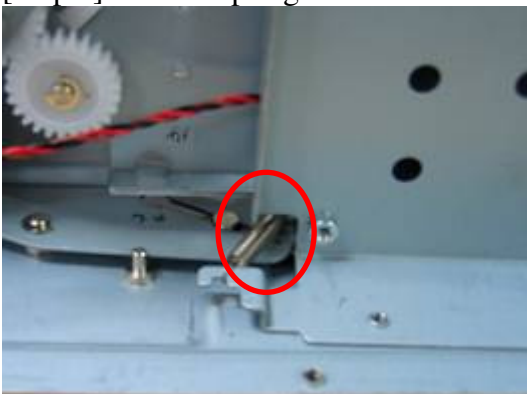

[Step 4] Remove 2 screws to take out the “WIRE PAPER_BOX_SNR 390MM BLUE ROHS”.

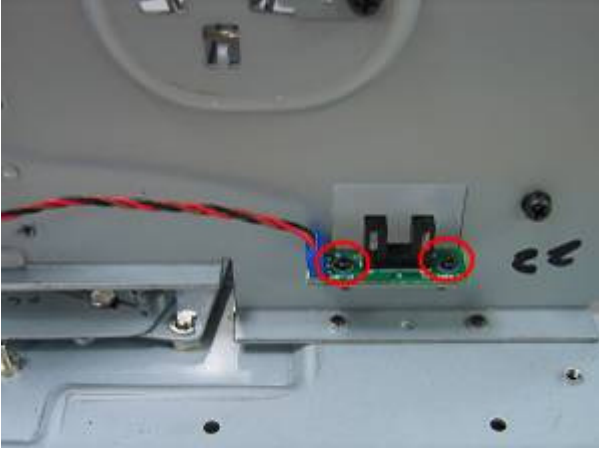

4-4-26 WIRE PAPER_TYPE 590MM ROHS

Parts Name	WIRE PAPER_TYPE 590MM ROHS	Part No.	40.D0911.R01
Tools	Phillips screwdriver (#2), screwdriver (small)	Procedure No.	26

Maintenance Parts: WIRE PAPER_TYPE 590MM ROHS (PAPER TYPE SENSOR)

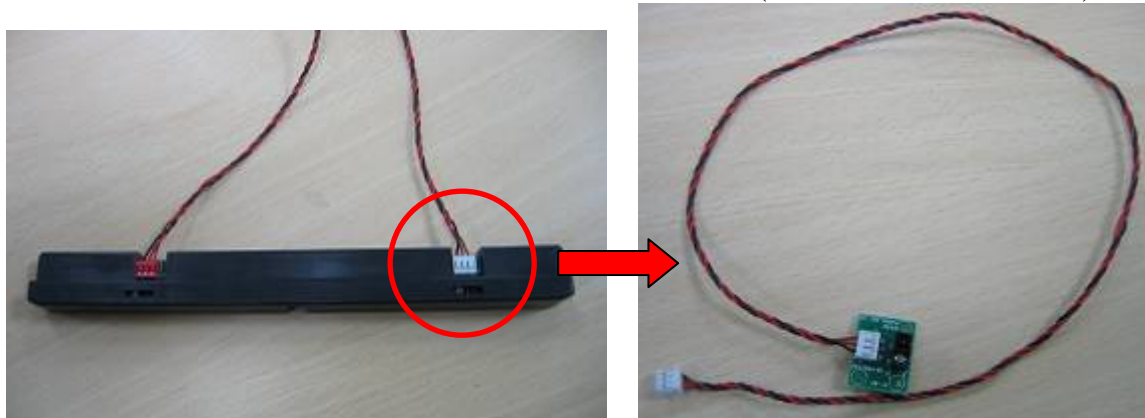

[Step 1] Remove the “ID_CASE_BACK_P510K”, “ID_COVER_MB_TOP_P510K”, “ID_CASE_TOP_P510K”, “ID_CASE_TOP_FRONT_P510K”, “ASSY LCD MODULE+ID CASE TOP+DECORATION”, “ASSY_CARD_READER”, “ID_CASE_RIGHT_P510K”, “ID_DOOR_RIGHT_P510K” and “ID_CASE_LEFT_P510K” according to **Procedure No. 1**.

[Step 2] Remove 3 screws from the bottom to take out the “SUPPORT_SNR_PAPER_OUT”.

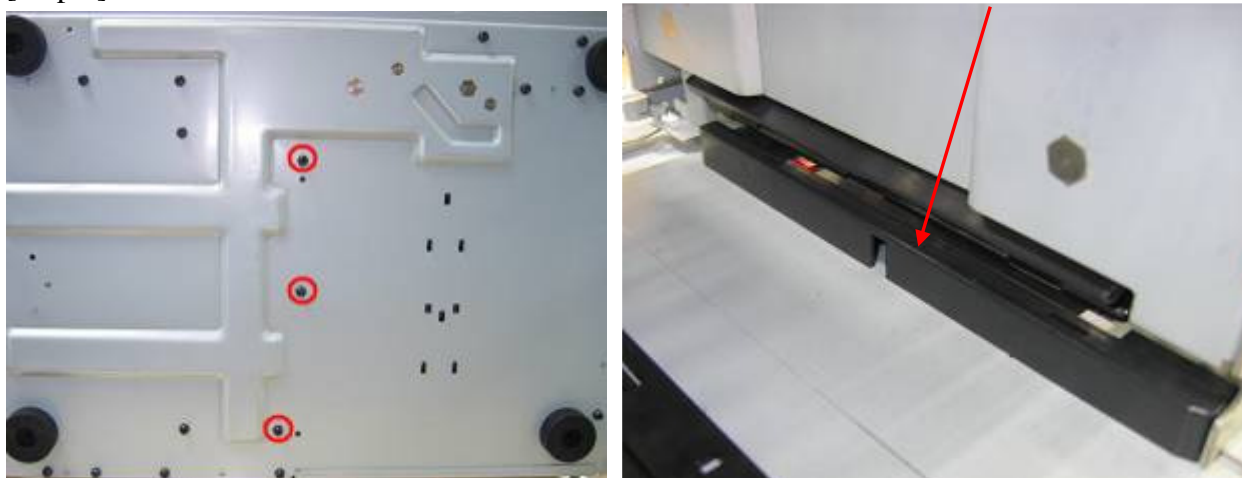

[Step 3] Remove 2 screws to take out the “WIRE PAPER_TYPE 590MM ROHS”.



4-4-27 WIRE PAPER_OUT 680MM ROHS

Parts Name	WIRE PAPER_OUT 680MM ROHS	Part No.	40.D0910.R01
Tools	Phillips screwdriver (#2), screwdriver (small)	Procedure No.	27

Maintenance Parts: WIRE PAPER_OUT 680MM ROHS (PAPER OUT SENSOR)



[Step 1] Remove the “ID_CASE_BACK_P510K”, “ID_COVER_MB_TOP_P510K”, “ID_CASE_TOP_P510K”, “ID_CASE_TOP_FRONT_P510K”, “ASSY LCD MODULE+ID CASE TOP+DECORATION”, “ASSY_CARD_READER”, “ID_CASE_RIGHT_P510K”, “ID_DOOR_RIGHT_P510K” and “ID_CASE_LEFT_P510K” according to **Procedure No. 1**.

[Step 2] Remove 3 screws from the bottom to take out the “SUPPORT_SNR_PAPER_OUT”.

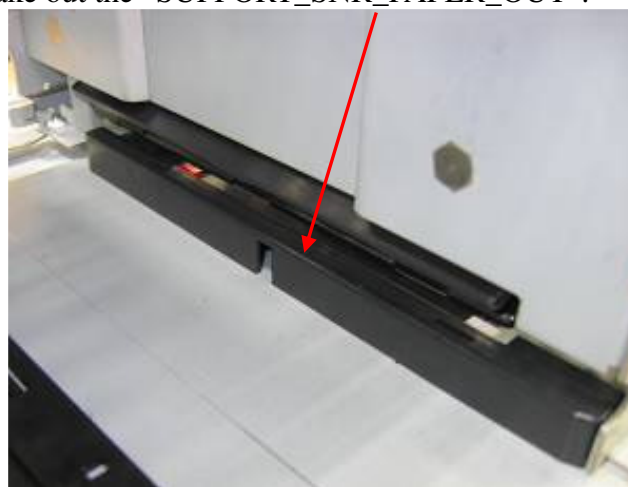
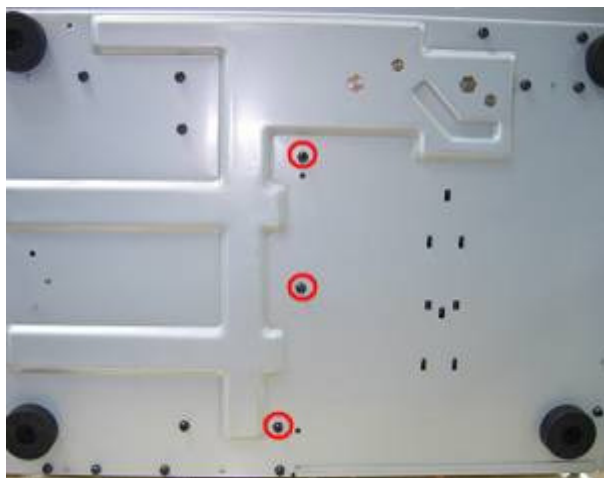

[Step 3] Remove 2 screws to take out the “WIRE PAPER_OUT 680MM ROHS”.



4-4-28 WIRE LE_FEED_SNR 490MM ROHS

Parts Name	WIRE LE_FEED_SNR 490MM ROHS	Part No.	40.D0902.R01
Tools	Phillips screwdriver (#2), screwdriver (small)	Procedure No.	28

Maintenance Parts: WIRE LE_FEED_SNR 490MM ROHS (LE SENSOR)

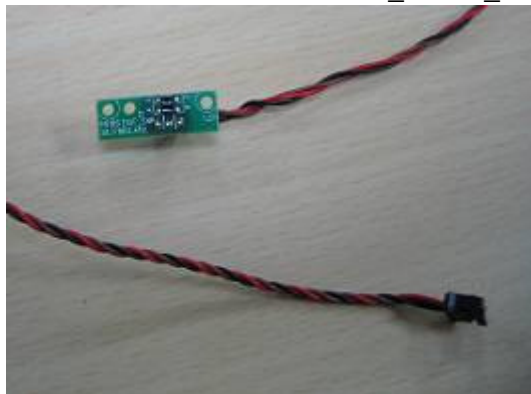

[Step 1] Remove the “ID_CASE_BACK_P510K”, “ID_COVER_MB_TOP_P510K”, “ID_CASE_TOP_P510K”, “ID_CASE_TOP_FRONT_P510K”, “ASSY LCD MODULE+ID CASE TOP+DECORATION “, “ASSY_CARD_READER”, “ID_CASE_RIGHT_P510K”, “ID_DOOR_RIGHT_P510K”, “ID_CASE_LEFT_P510K”, “P510K PHOTO PRINTER KIOSK M/B”, “POWER BD P510K TO KIOSK SYSTEM”, “FRAME_MID_P510K”, “FRMAE_MAIN_P510K”, “ROLLER_EXIT_PINCH_CUTTER_A5”, “LINKAGE_MODULE_P510S”, “TRAY_EXIT_ASSY “, “CAPSTAN_ROLLER_A5”, “ROLLER_PLATEN_NEW_A5 “, “ROLLER_PINCH_A5” and “TRAY_FEED” according to [Procedure No. 1, 2, 3, 4, 14, 15, 17, 18, 20, 21, 22 and 23](#).

[Step 2] Remove 4 screws.



[Step 3] Remove 2 screws and 1 connector to take out the “WIRE LE_FEED_SNR 490MM ROHS”.



4-4-29 WIRE JAM_SNR 340MM ROHS,WIRE JAM_LED_290MM ROHS

Parts Name	WIRE JAM_SNR 340MM ROHS WIRE JAM_LED_290MM ROHS	Part No.	40.D0914.R01 40.D0915.R01
Tools	Phillips screwdriver (#2), screwdriver (small)	Procedure No.	29

Maintenance Parts:

1. WIRE JAM_SNR 340MM ROHS (JAM SENSOR)
2. WIRE JAM_LED_290MM ROHS (JAM LED)



[Step 1] Remove the “ID_CASE_BACK_P510K”, “ID_COVER_MB_TOP_P510K”, “ID_CASE_TOP_P510K”, “ID_CASE_TOP_FRONT_P510K”, “ASSY LCD MODULE+ID CASE TOP+DECORATION “, “ASSY_CARD_READER”, “ID_CASE_RIGHT_P510K”, “ID_DOOR_RIGHT_P510K”, “ID_CASE_LEFT_P510K”, “P510K PHOTO PRINTER KIOSK M/B”, “POWER BD P510K TO KIOSK SYSTEM”, “FRAME_MID_P510K”, “FRMAE_MAIN_P510K”, “LINKAGE_MODULE_P510S”, “ROLLER_EXIT_PINCH_CUTTER_A5” and “TRAY_EXIT_ASSY” according to [Procedure No. 1, 2, 3, 4, 14, 15, 17 and 18](#).

[Step 2] Remove 4 screws and 1 connector to take out the “WIRE JAM_SNR 340MM ROHS & WIRE JAM_LED_290MM ROHS”.

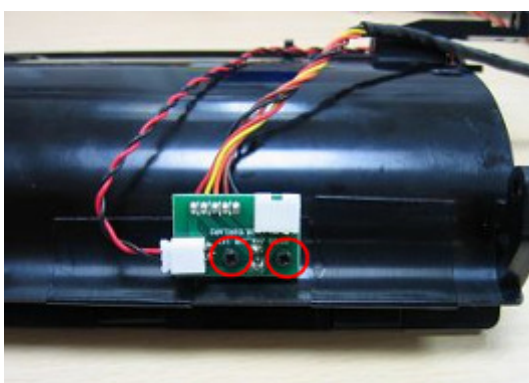

4-4-30 WIRE RBN_SNR_LEFT 120MM ROHS,WIRE RBN_SNR_RIGHT 160MM ROHS,WIRE RBN_LED_LEFT 350MM ROHS,WIRE RBN_LED_RIGHT 470MM ROHS

Parts Name	WIRE RBN_SNR_LEFT 120MM ROHS,WIRE RBN_SNR_RIGHT 160MM ROHS,WIRE RBN_LED_LEFT 350MM ROHS,WIRE RBN_LED_RIGHT 470MM ROHS	Part No.	40.D0907.R01 40.D0908.R01 40.D0912.R01 40.D0913.R01
Tools	Phillips screwdriver (#2), screwdriver (small)	Procedure No.	30

Maintenance Parts:

1. WIRE RBN_SNR_LEFT 120MM ROHS (RIBBON SENSOR_LEFT)
2. WIRE RBN_SNR_RIGHT 160MM ROHS (RIBBON SENSOR_RIGHT)
3. WIRE RBN_LED_LEFT 350MM ROHS (RIBBON LED_LEFT)
4. WIRE RBN_LED_RIGHT 470MM ROHS (RIBBON LED_RIGHT)

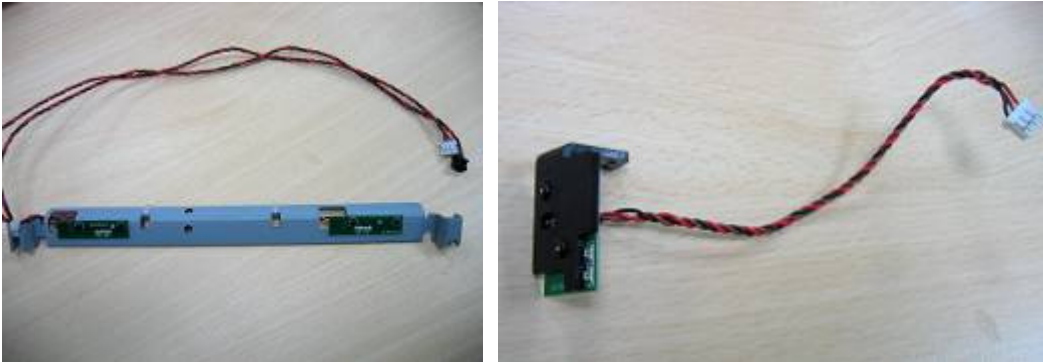

[Step 1] Remove the “ID_CASE_BACK_P510K”, “ID_COVER_MB_TOP_P510K”, “ID_CASE_TOP_P510K”, “ID_CASE_TOP_FRONT_P510K”, “ASSY LCD MODULE+ID CASE TOP+DECORATION”, “ASSY_CARD_READER”, “ID_CASE_RIGHT_P510K”, “ID_DOOR_RIGHT_P510K”, “ID_CASE_LEFT_P510K”, “P510K PHOTO PRINTER KIOSK M/B”, “POWER BD P510K TO KIOSK SYSTEM”, “FRAME_MID_P510K”, “FRMAE_MAIN_P510K”, “ROLLER_EXIT_PINCH_CUTTER_A5”, “LINKAGE_MODULE_P510S”, “TRAY_EXIT_ASSY”, “CAPSTAN_ROLLER_A5” and “HOLDER_SENSOR_RBN_LEFT” according to [Procedure No. 22](#) step 1, 2 and 3.

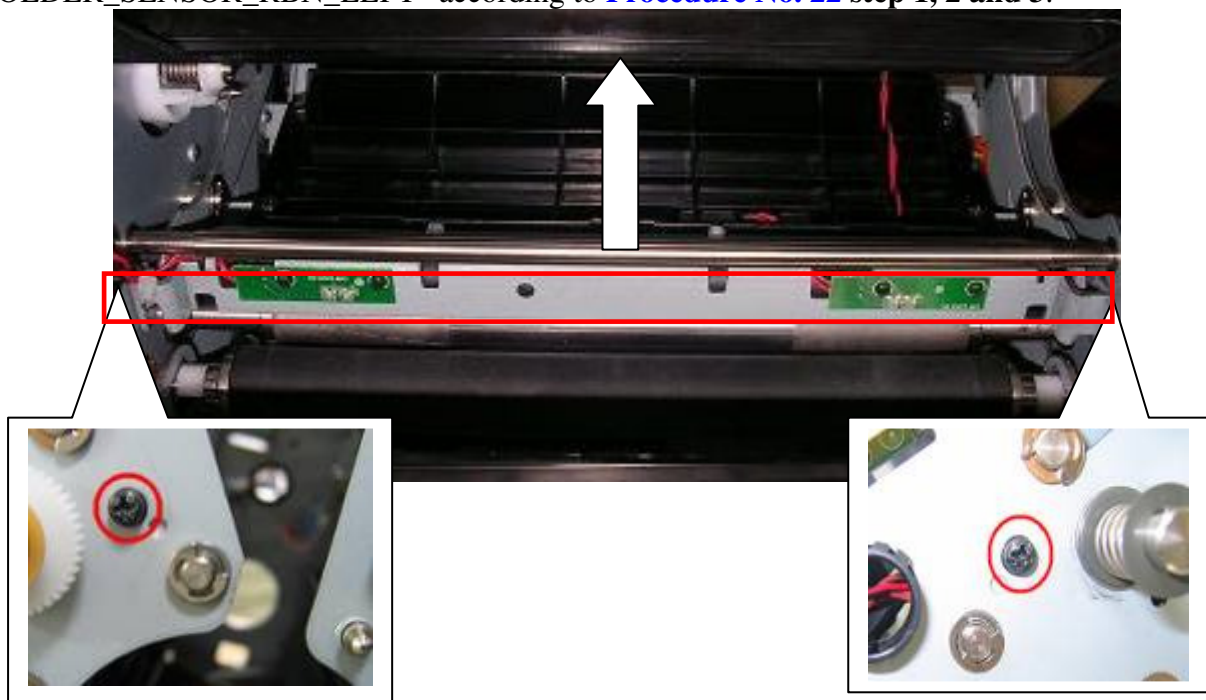

[Step 2] Remove 4 screws (from the “HOLDER_SENSOR_RBN_LEFT”) to take out the “WIRE RBN_LED_LEFT 350MM ROHS” and “WIRE RBN_LED_RIGHT 470MM ROHS”.

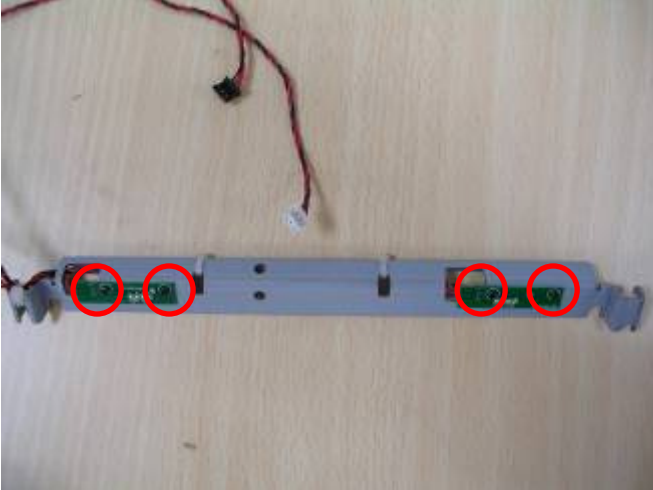

[Step 3] Remove 2 screws (from the “LINKAGE_MODULE_P510S”) and 2 connectors to take out the “WIRE RBN_SNR_LEFT 120MM ROHS” and “WIRE RBN_SNR_RIGHT 160MM ROHS”.

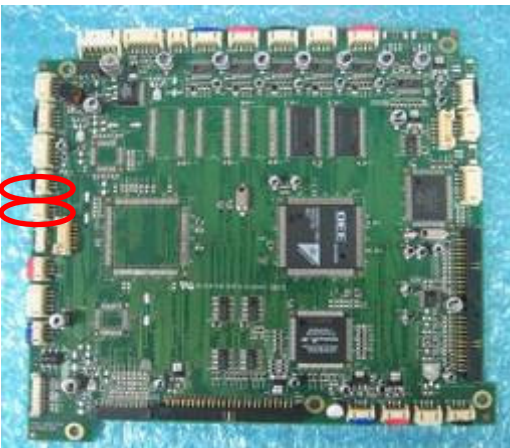
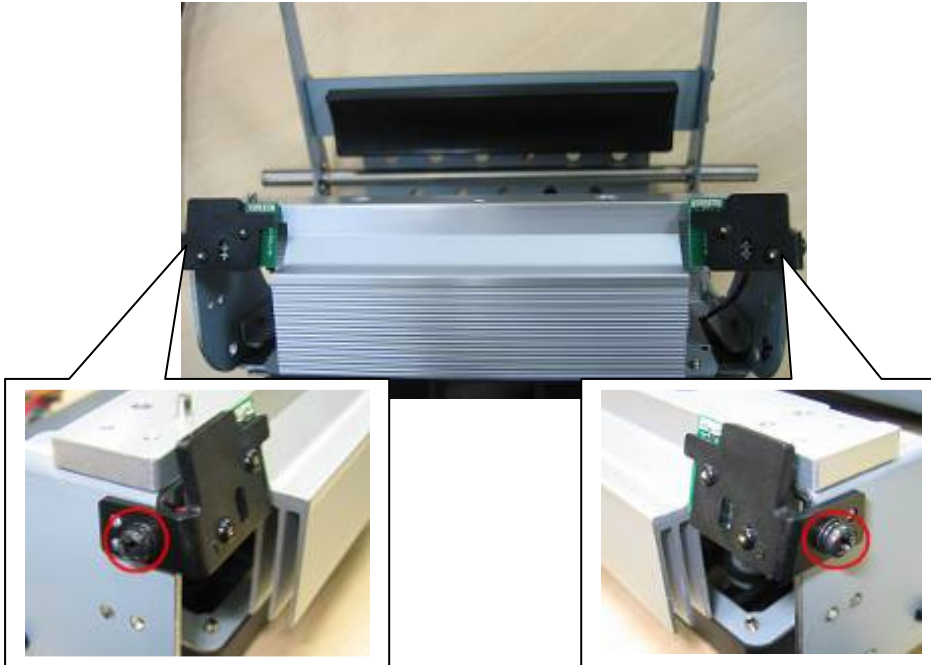

4-4-31 WIRE_CAM_PINCH 180MM ROHS

Parts Name	WIRE_CAM_PINCH 180MM ROHS	Part No.	40.D0916.R01
Tools	Phillips screwdriver (#2), screwdriver (small)	Procedure No.	31

Maintenance Parts: WIRE_CAM_PINCH 180MM (Cam sensors)



[Step 1] Remove the “ID_CASE_BACK_P510K”, “ID_COVER_MB_TOP_P510K”, “ID_CASE_TOP_P510K”, “ID_CASE_TOP_FRONT_P510K”, “ASSY LCD MODULE+ID CASE TOP+DECORATION “, “ASSY_CARD_READER”, “ID_CASE_RIGHT_P510K”, “ID_DOOR_RIGHT_P510K”, “ID_CASE_LEFT_P510K”, “P510K PHOTO PRINTER KIOSK M/B”, “POWER BD P510K TO KIOSK SYSTEM” and “FRAME_MID_P510K” according to to [Procedure No. 1, 2, 3 and 4](#).

[Step 2] Remove 4 screws to take out the the “FRAME_STEPPING_P510S”.

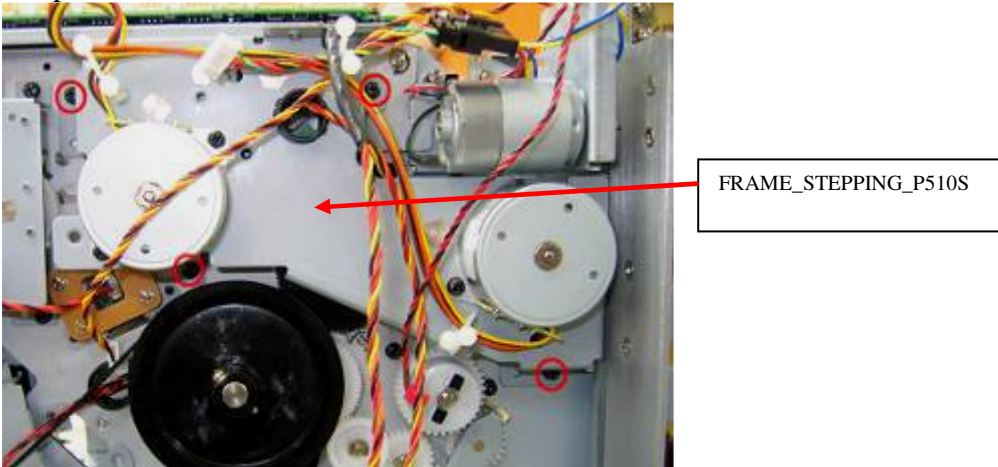

[Step 3] Remove 2 screws (from the left side) and 1 connector to take out the “WIRE_CAM_PINCH 180MM ROHS”.

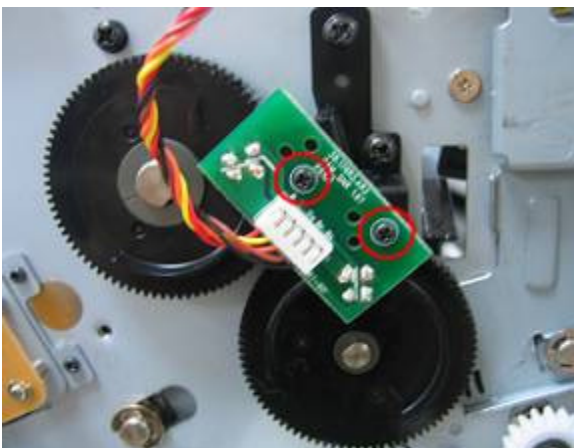

4-4-32 WIRE SMART_CHIP 240MM ROHS

Parts Name	WIRE SMART_CHIP 240MM ROHS	Part No.	40.D0906.R01
Tools	Phillips screwdriver (#2), screwdriver (small)	Procedure No.	32

Maintenance Parts: WIRE SMART_CHIP 240MM (IC CHIP SENSOR)



[Step 1] Remove the “ID_CASE_BACK_P510K”, “ID_COVER_MB_TOP_P510K”, “ID_CASE_TOP_P510K”, “ID_CASE_TOP_FRONT_P510K”, “ASSY LCD MODULE+ID CASE TOP+DECORATION “, “ASSY_CARD_READER”, “ID_CASE_RIGHT_P510K”, “ID_DOOR_RIGHT_P510K”, “ID_CASE_LEFT_P510K”, “P510K PHOTO PRINTER KIOSK M/B”, “POWER BD P510K TO KIOSK SYSTEM” and “FRAME_MID_P510K” according to to **Procedure No. 1, 2, 3 and 4.**

[Step 2] Remove 4 screws to take out the the “FRAME_STEPPING_P510S”.

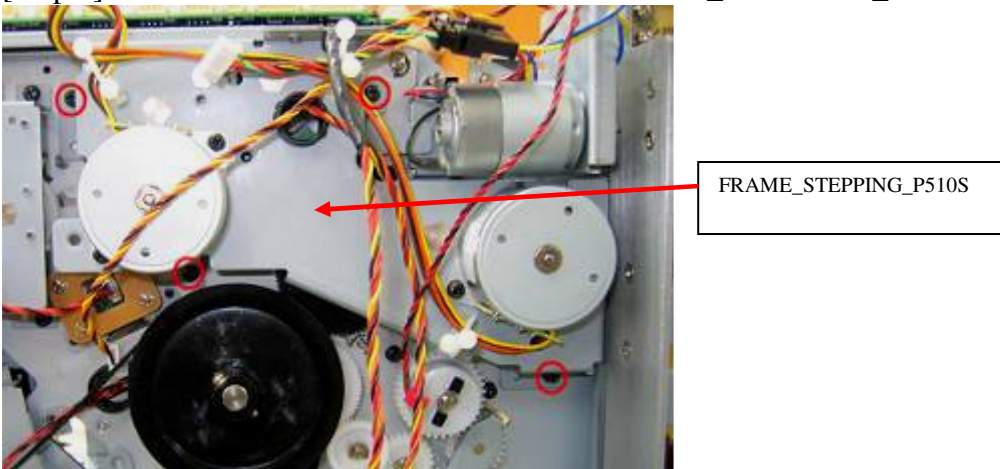

[Step 2] Remove 2 screws and 1 connector to take out the “WIRE SMART_CHIP 240MM ROHS“.

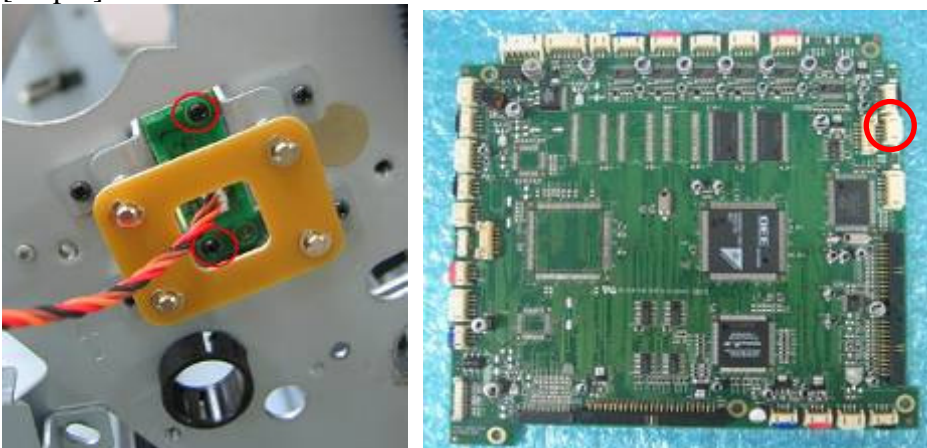

Chapter 5: Maintenance

◆ Failure Inspection

- **Clean Dust** – When printer had been used in dusty environment or used for a period of time, you have to check these points to clean the dust to maintain the printer performance.



Heat Sink



Fan

- Check connectors – To make sure whole connectors on IPC connect well when you encountered problem.

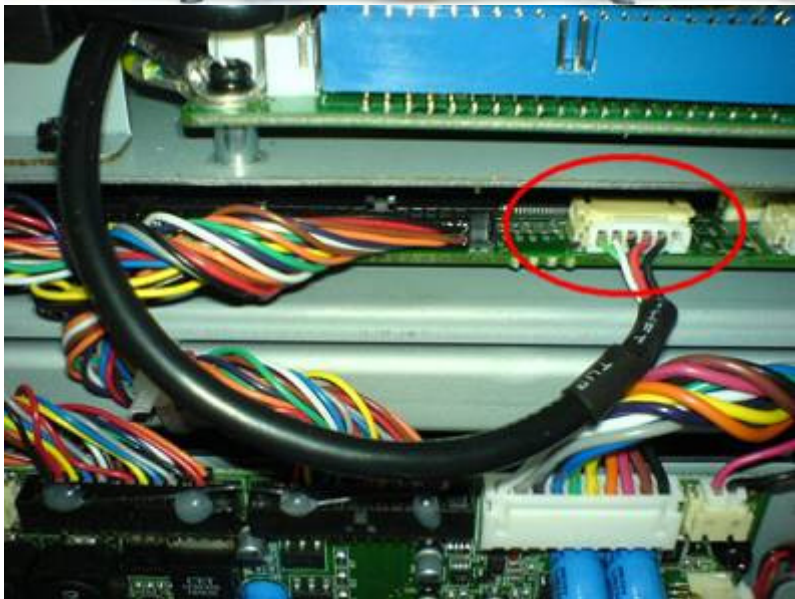
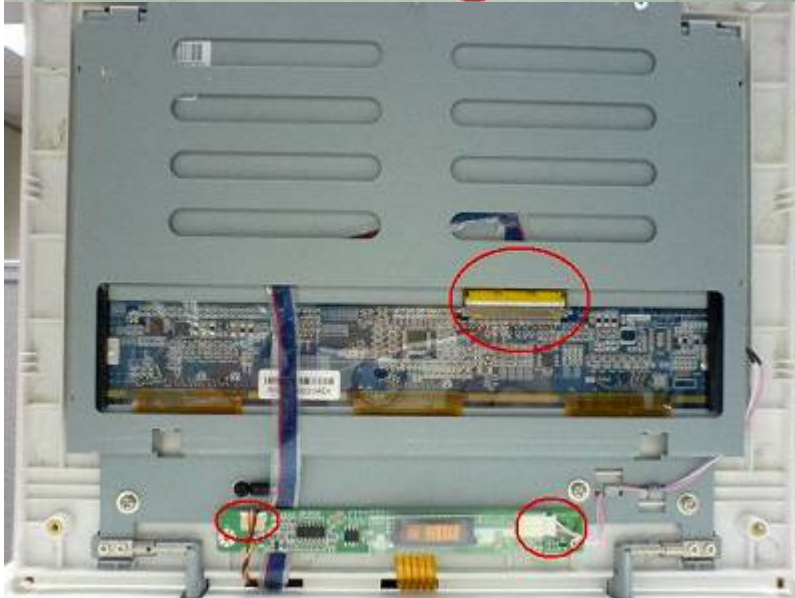
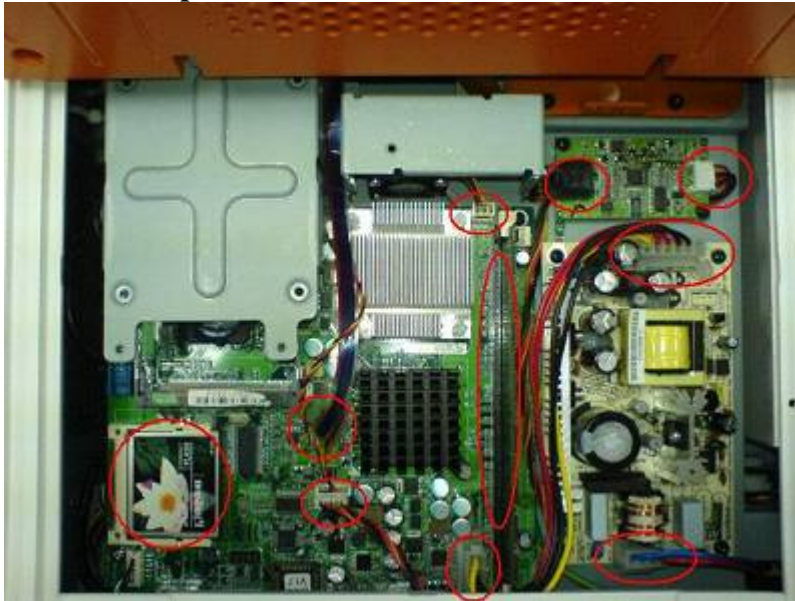

Chapter 6: Adjustment

Please make sure you got the latest version of this “HTools” from HiTi service Team (service2@hiti.com)



Any adjustment that needs disassembly of appearance cover, the door sensor is required to be enabled (pressed-in) in order to have the printer is ready mode.

- **ADF Test (Automatic Document Feeding function test)**

Please make sure the paper roll & cassette is properly installed, then process the ADF testing to confirm the ADF function is normal.

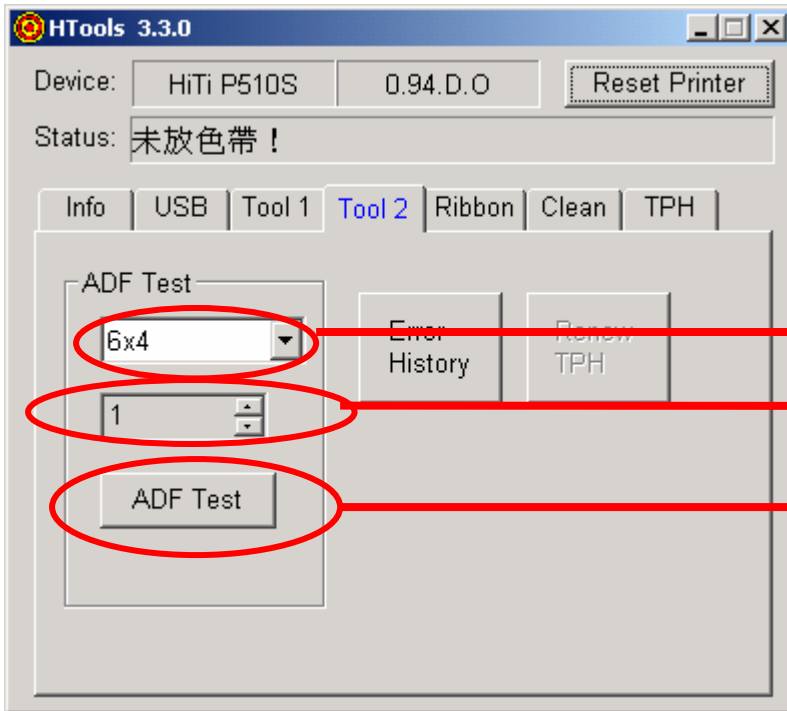

Be sure to select correct paper size

Testing times of ADF

Press the test button to start the paper feeding function.

● **TPH Voltage Calibration (Printout density adjustment)**

Symptom Explanation:

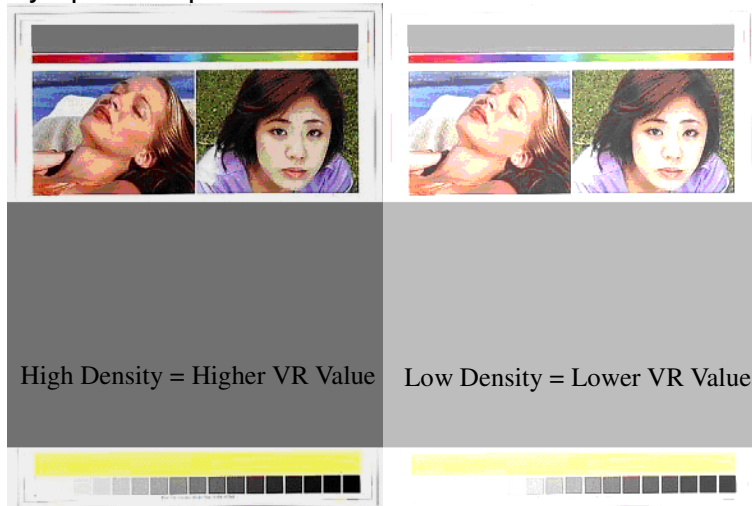

1. Before replacing TPH, click **Print Chart(Before change TPH)** Button to print 3 reference charts first.(P1, P2, P3)

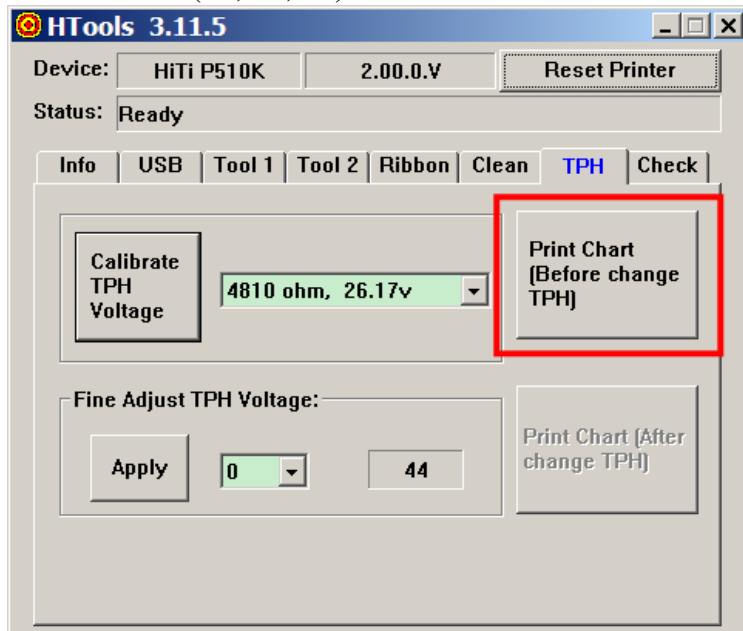

2. According to new TPH resistor (Ω), choose the closest TPH Ω and Voltage.

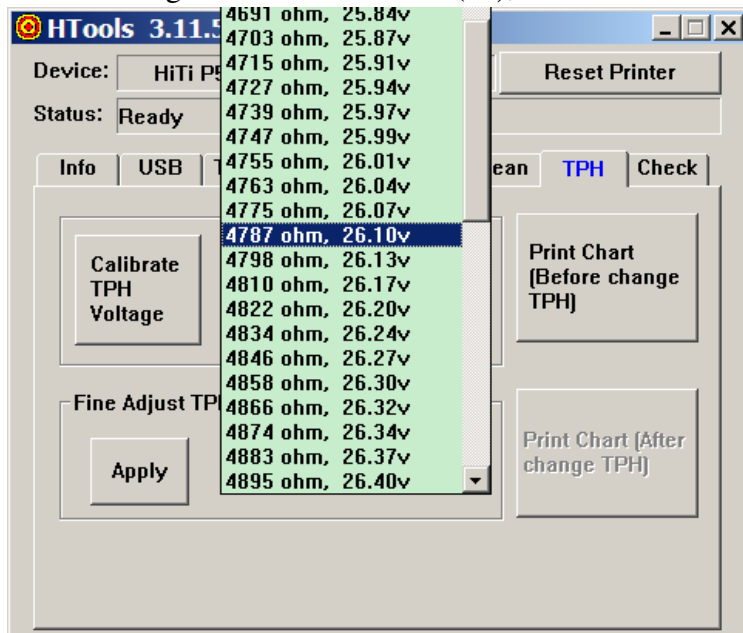

3. Click **Calibrate TPH Voltage** Button to start the calibration.

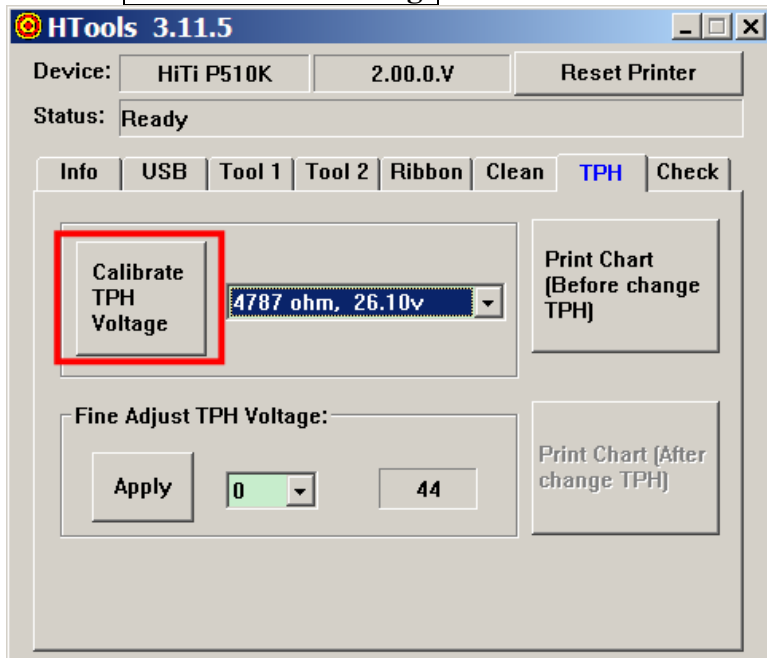

4. Click **Print Chart(After change TPH)** button to print the result chart (P4) after calibrated voltage and then compare to P1, P2, P3

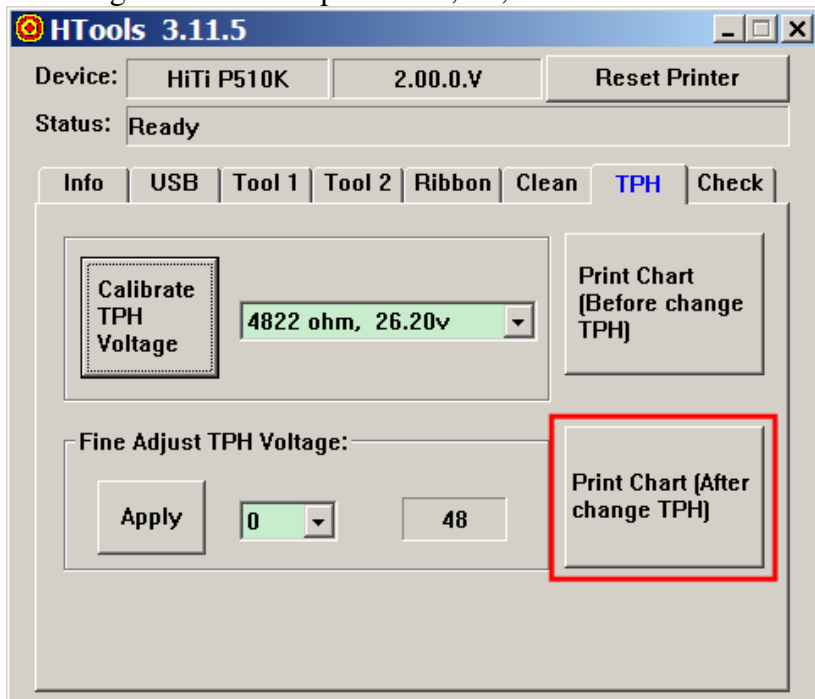

5. If the color of P4 is too dark, try to decrease the number **-1**

If the color of P4 is too light, try to increase the number **+1**

Color density should be in P1, P2 and P3 color density range. Keep 'Fine Adjust TPH Voltage' if the color density is not in the range of P1, P2 and P3.

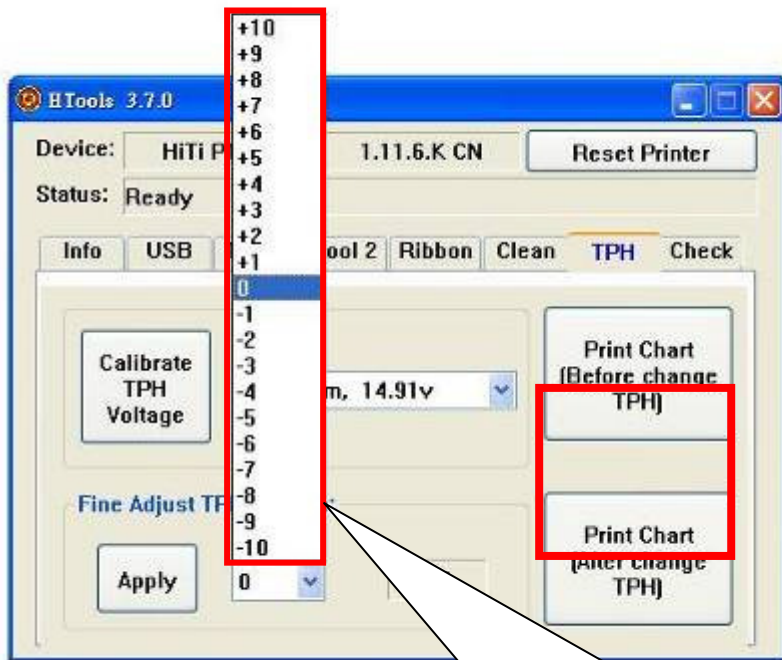

+1, increasing number and the color getting darker
-1, decreasing number and the color getting lighter

● **Ribbon Search & Ribbon LED Calibrate**

The P510K uses black bar to detect ribbon colors, so there will only be a high value and low value, calibration value can still maintain the accuracy by automatic adjustment of this tool shown below:

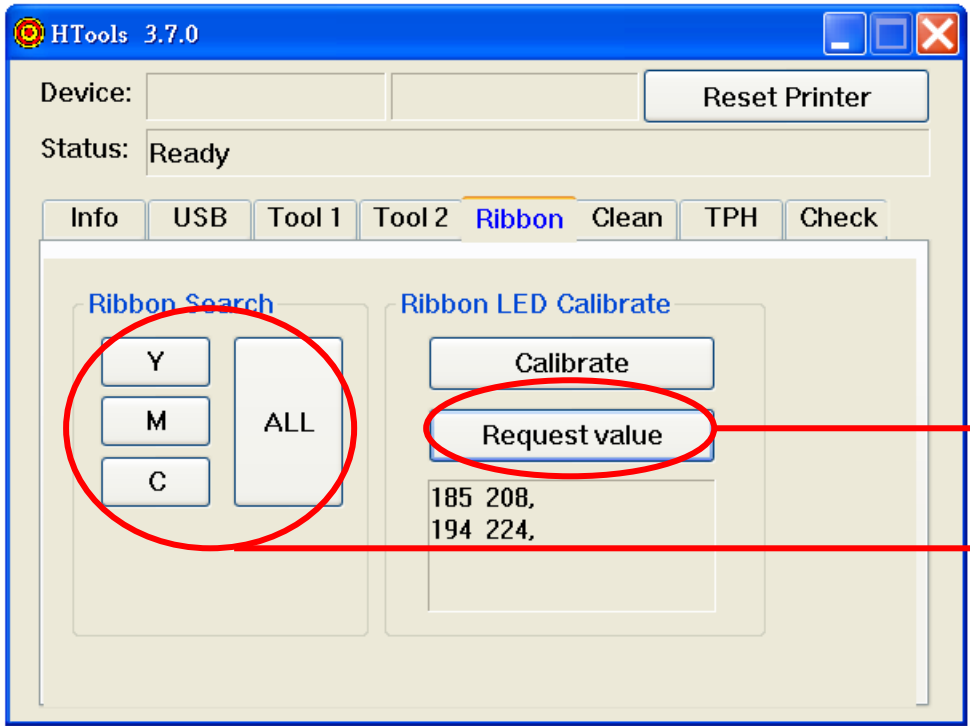

Request Value and Calibrate value is to test the LED and sensors are working properly

Ribbon Search function is to test the ribbon color detection.

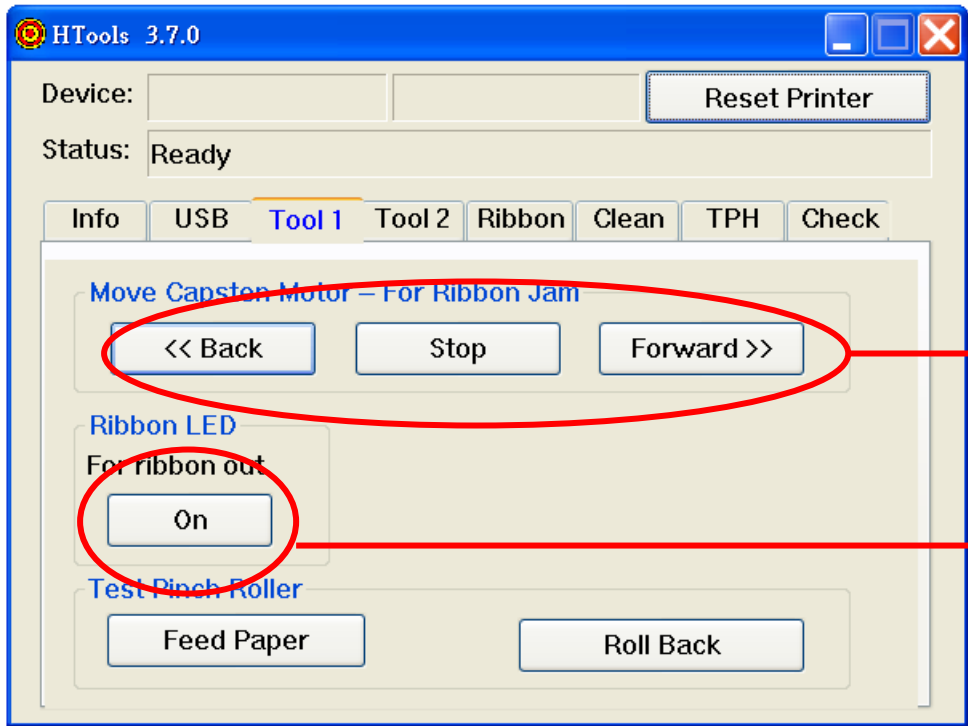

Besides using the manual control of the capstan roller, with the help of Htools you can also move the capstan roller automatically.

During testing of the Ribbon LED hardware you can use this switch to enable the Ribbon LED. (note that this LED in P510K is infrared, so its not visible by naked eye)

Chapter 7: Gear List

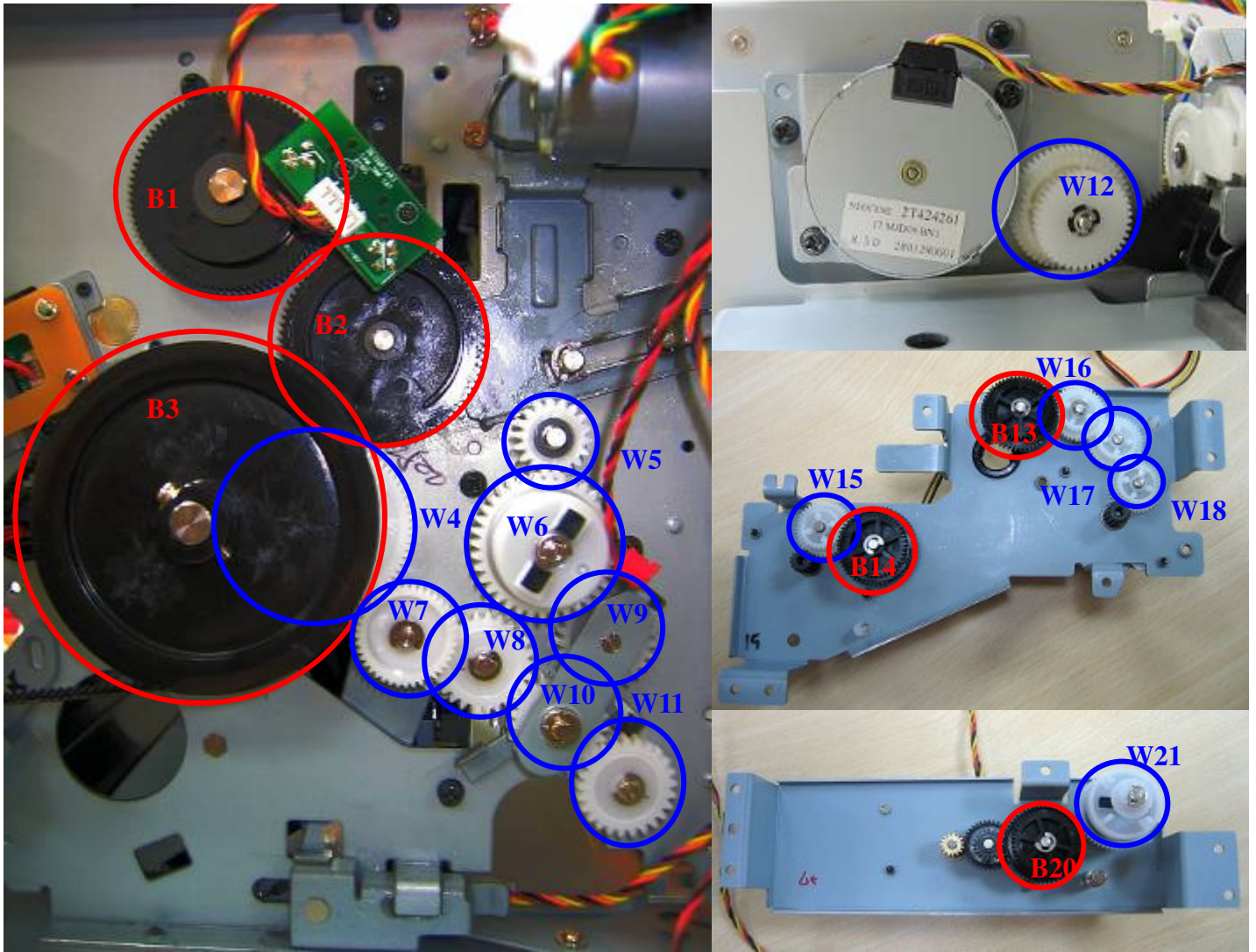

No.	Part Number	Gear Name	No.	Part Number	Gear Name
B1	65.D0914.001	GEAR_CAM_TPH_2	W12	56.P1002.002	BARRICADE_TQL_G2
B2	65.D0913.001	GEAR_CAM-LINK_DOOR_2		56.P1005.G02	GEAR_RBN_TQL_G2
B3	65.D0911.001	PULLEY_CAPSTAN_COMPOUND		60.P1001.001	FELT_TQL_G2
W4	65.D0904.001	GEAR_DRIVE_IDLE		65.D0915.001	GEAR_DRIVER_TQL_DOOR_CUT
W5	65.D0921.001	GEAR_LINKER		73.81201.306	E RING 3X7.1X0.6T STEEL
W6	65.D0909.001	GEAR_TQL_TAKE_C		73.81241.204	E-RING D2X5X0.4T NI
W7	65.D0903.001	GEAR_DRIVE		74.13H53.6P0	MACH PAN FLAT+SPRING WASHER M3
W8	65.D0907.001	GEAR_SWING_A5_M1	B13	56.P0829.G01	GEAR_ROLLER_EXIT
W9			B14		
W10			W15	56.D0103.G21	IDLE_GEAR2_FEEDROLLER
W11			W16		
			W17		
			W18		
			B20	56.P0829.G01	GEAR_ROLLER_EXIT
			W21	65.D0902.001	GEAR_TQL_DRIVE_TYPEC

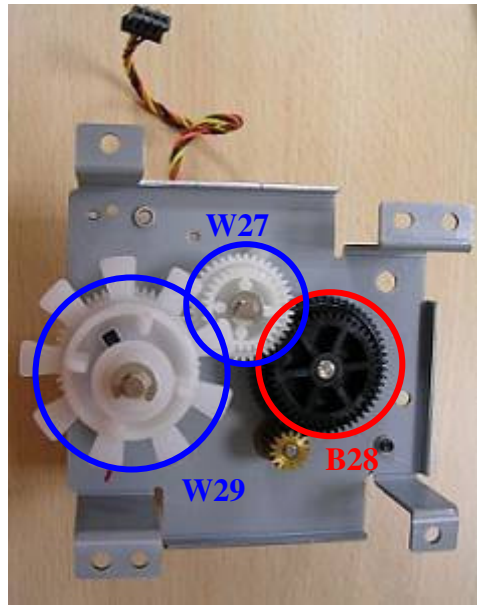
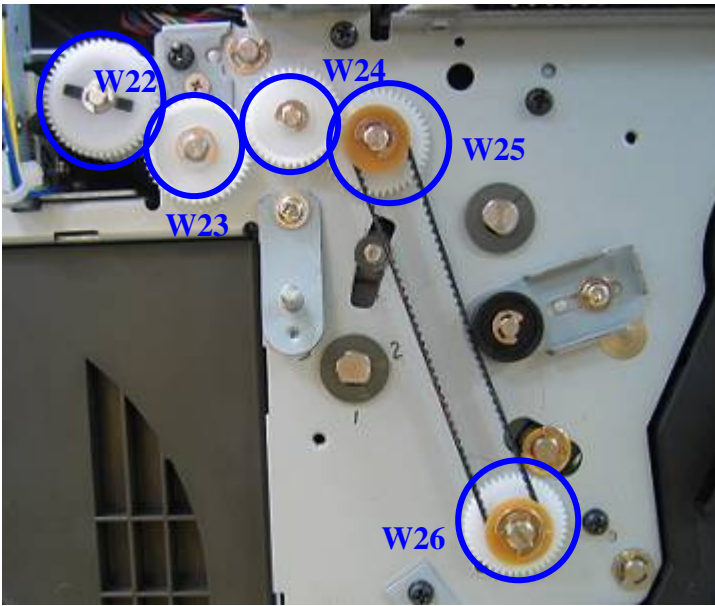

No.	Part Number	Gear Name	No.	Part Number	Gear Name
W22	65.D0917.001	GEAR_TQL_DRIVE_ROLLER_EXIT	W27	56.D0103.G21	IDLE_GEAR2_FEEDROLLER
	46.D0905.001	TQL_ROLLER_EXIT(OTL VS6-200B	B28	56.P0829.G01	GEAR_ROLLER_EXIT
	65.D0917.001	GEAR_TQL_DRIVE_ROLLER_EXIT	W29	56.D0921.001	CLAW_SPOOL_SUPPLY
W23	65.D0920.001	PULLEY_ROLLER_EXIT_MXL		65.C0104.011	GE_TQL_DRIVER_NEW_C1
W24	65.D0916.001	GEAR_IDLE_ROLLER_EXIT		46.D0902.001	TQL_ORING_SUPPLY
W25	65.D0920.001	PULLEY_ROLLER_EXIT_MXL			
W26	65.D0919.001	PULLEY_CAPSTAN_MXL			

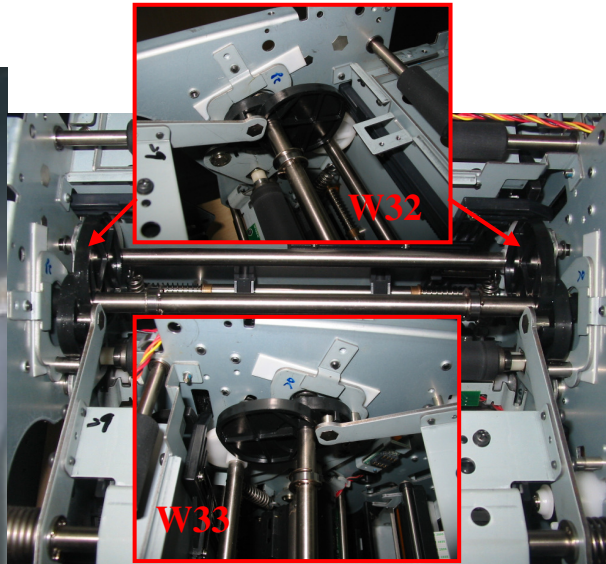
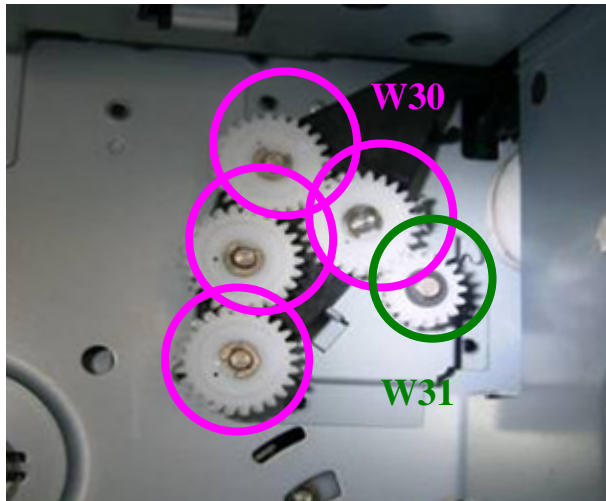

No.	Part Number	Gear Name
W30	65.D0907.001	GEAR_SWING_A5_M1
W31	65.D0921.001	GEAR_LINKER
W32	56.D0958.H04	CAM_TPH_L_2
W33	56.D0959.H04	CAM_TPH_R_2

Chapter 8: Error Message

Error Message	RED LED blinking times	Possible Cause	Solution	
Cover Open	1 time	<ol style="list-style-type: none"> The printer cover is not closed properly. Connection of the Cover Sensor is not good. The Cover Sensor is damaged. 	<ol style="list-style-type: none"> Open and close the cover again. Check connection of the Cover Sensor. Change the Cover Sensor. 	
Ribbon Missing	2 times	<ol style="list-style-type: none"> The ribbon cartridge is not inserted properly. The ribbon cartridge is damaged. Connection of the IC Chip Sensor is not good. The IC Chip Sensor is damaged. 	<ol style="list-style-type: none"> Insert the ribbon cartridge again. Try with another ribbon set. Check connection of the IC Chip Sensor. Change the IC Chip Sensor. 	
Ribbon Out	3 times	<ol style="list-style-type: none"> There is no more ribbon frames inside the ribbon cartridge. Connection of the Ribbon LED & Sensor (left & right) is not good. The Ribbon LED (left & right) is damaged. The Ribbon Sensor (left & right) is damaged 	<ol style="list-style-type: none"> Confirm the ribbon is finished. Change the ribbon cartridge. Check connection of Ribbon LED and Sensor (left& right). Change the Ribbon LED (left & right). Change the Ribbon Sensor (left & right). 	
Paper Out	4 times	<ol style="list-style-type: none"> Paper has run out. The Paper roll is not properly installed. Connection of the Paper Out Sensor is not good. The Paper Out Sensor is damaged. 	<ol style="list-style-type: none"> Put a new set of paper roll. Install the paper roll again. Check connection of the Paper Out Sensor. Change the Paper Out Sensor. 	
Paper Jam*	5 times	Code 21	USB disconnected between PC and printer	Change another USB port or use 2. 0 USB Hub to connecting.
		Code 22	There is paper jammed inside printer when power on	This error happens except 26,27,28 error happened. TBD
		Code 23	Jam sensor can't detected paper after LE sensor detected during paper loading (It might be these 2 sensors NG)	<ol style="list-style-type: none"> Take out jammed paper. Replace these 2 sensors.
		Code 24	Eject sensor can't detected paper when printing finished (It might be eject sensor NG)	<ol style="list-style-type: none"> Take out jammed paper. Replace Eject sensor.
		Code 25	When paper needs to rewind back during printing, but it can't.	<ol style="list-style-type: none"> Take out jammed paper. Replace LE/Jam/Eject sensors.
		Code 26	Eject sensor detected paper when power on.(Paper stuck nearby)	<ol style="list-style-type: none"> Take out jammed paper. TBD
		Code 27	Jam sensor detected paper when power on.(Paper stuck nearby)	<ol style="list-style-type: none"> Take out jammed paper. TBD
		Code 28	LE sensor detected paper when power on.(Paper stuck nearby)	<ol style="list-style-type: none"> Take out jammed paper. TBD
		Code 29	<ol style="list-style-type: none"> Ribbon melt Paper jam near the exit Capstan roller works abnormally Ribbon cannot be rolled smoothly and correctly 	<ol style="list-style-type: none"> Change Capstan roller or Jam sensor. Change Cover_TPH_A5 or Peeler_Press_A5RT. Change capstan motor
		Code 30	<ol style="list-style-type: none"> Paper jam near the TPH Capstan roller works abnormally Ribbon cannot be rolled smoothly and correctly 	<ol style="list-style-type: none"> Cover_TPH_A5, Peeler_Press_A5RT. Change Capstan roller or Jam sensor. Change capstan motor
Paper Mismatch	6 times	Paper type does not match the ribbon.	<ol style="list-style-type: none"> Check the paper and ribbon were for the same size or not. 	
Cam Platen Error	7 times	Position of the Cam Platen has been misaligned or other hardware mechanism error	<ol style="list-style-type: none"> Check connection of the Cam Platen Sensor. Change Cam Platen Sensor. Change Cam Platen Motor. Change Printer Main Board. 	
Cam Pinch Error	8 times	Position of the Cam Pinch has been misaligned or other hardware mechanism error	<ol style="list-style-type: none"> Check connection of the Cam Pinch Sensor. Change Cam Pinch Sensor. 	

			3. Change Cam Pinch Motor. 4. Change Printer Main Board.
Nvram Error	9 times	Main BD internal error	Change Printer Main BD
Ribbon Chip Error	10 times	1. Ribbon Chip faulty. 2. Ribbon cartridge is damaged. 3. the Chip Sensor is damaged.	1. Use an eraser to clean the ribbon chip. 2. Change the Chip Sensor.
ADC Error	12 times	TPH heating problem	1. Check connection of the TPH Wire and Flat Cable between the TPH Board and Printer Main BD. 2. Change Flat Cable. 3. Change the TPH Wire. 4. Change the TPH Board. 5. Change the TPH ASSY.
FWChecksum Error	13 times	Firmware problem	Rewrite firmware
Printer Error	14 times	TBD	TBD
Cutter Error	15 times	Cutter Stuck or faulty	1. Clean wastepaper. 2. Change the Cutter Sensor. 3. Change the Cutter ASSY.

*Needs Htools software to see Code 21~30

Error Code

Error Code	Description
0x0000001A	Printer has no response.
0x0000002A	Printer has no response.
0x0000274D	Connection refused.
0x00000080	Printer is off-line!!
0x11000002	Data format error! This print job will be cancelled.
0x11000008	System resource is insufficient to print this page. Please reboot your system.
0x000100FE	Paper roll mismatch!
0x000301FE	Command sequence error.
0x00030001	SRAM error!
0x00030101	Cutter error!
0x00030201	ADC error!
0x00030301	NVRAM R/W error!
0x00030302	Check sum error - SDRAM!
0x00030402	DSP code check sum error!
0x00030501	Cam Platen error!
0x00030601	Cam pinch error!
0x00030701	Firmware write error!
0x00030502	Nvram CRC error!
0x00030602	Check sum error - SRAM!
0x00030702	Check sum error - FLASH!
0x00030802	Check sum error - wrong firmware!
0x00031201	Nand flash error.
0x00050001	Cover open/Ribbon cassette door open! Please close the door before continue.
0x00050101	Cover open/Ribbon cassette door open! Please close the door before continue.
0x00080004	Ribbon missing! Please put in the ribbon before continue.

0x00080103	Out of ribbon! Please reload a new ribbon cartridge.
0x00080104	Out of ribbon! Please reload a new ribbon cartridge.
0x00080105	Printing fails!! Please reload a new ribbon cartridge.
0x000802FE	Ribbon error! Please reload a new ribbon cartridge
0x00080007	Ribbon is just inserted.
0x000804FE	Ribbon IC R/W error.
0x000806FE	Unsupported ribbon.
0x000808FE	Unknown ribbon.
0x00030000	Paper Jam! Please follow the instructions on printer LCD monitor before continuing the print job.
0x0003000F	Paper Jam! Printer has no response.
0x00008000	Paper out or feeding error. Please pull out the paper box and insert again after papers refill or sorting.
0x00008010	Paper roll mismatch! Please put in the correct paper roll before continue.
0x00080200	Ribbon type mismatch! Please put in the correct ribbon cassette before continue printing.
0x00007540	Printer is at Standalone Mode! Please exit Standalone Mode before continue printing.

Servicer Code	Check Item
Printer Cannot Get Ready (Red LED Fast Blinking)	1. Update printer firmware. 2. Change the Printer Main Board.
No Power	1. Change the Power Board. 2. Change the Main Board.
Booting Fail	1. Adjust BIOS booting sequency. 2. Reset BIOS. 3. Change the system CF card.
Pixel Registration	1. Change the Pinch Roller. 2. Change the Capstan Roller.
Uniformity	Change the TPH.
TPH Pixel Fail	Change the TPH.
Density	1. Adjust voltage of the Printer TPH Board. 2. Change the TPH Board. 3. Change the TPH.
Wrinkle	1. Change the ribbon cartridge. 2. Adjust voltage of the Printer TPH Board. 3. Change the TPH
Printout Contamination	Clean
Scratch	Clean
Horizontal Line	1. Change the TQL. 2. Change the Pinch Roller. 3. Change the Platen Roller. 4. Change the Printer Main Board. 5. Change the Bearing_Capstan.
Vertical Line	1. Change the TPH. 2. Change the Printer Main Board.
Debris	1. Clean the Capstan Roller. 2. Clean the Pinch Roller.
Chart Abnormal	1. Change/Reconnect the TPH Wire. 2. Change/Reconnect the Flat Cable. 3. Change the Bushing_Platen. 4. Change the Spring_Pinch. 5. Change the Printer Main BD.
Unsupported Ribbon	Change the ribbon cartridge.
Ribbon Error	Change the ribbon cartridge.
Print Fail	1. Confirm the ribbon is finished. Change the ribbon cartridge. 2. Check connection of Ribbon LED and Sensor (left& right). 3. Change the Ribbon LED (left & right). 4. Change the Ribbon Sensor (left & right).
Skew	1. Change the Pinch Roller. 2. Change the Capstan Roller. 3. Change the Bushing_Platen. 4. Change the Spring_Pinch.
Artificial Case	-
Ribbon Jam	1. Clean 2. Check connection of Ribbon LED and Sensor (left& right). 3. Change the Ribbon LED (left & right). 4. Change the Ribbon Sensor (left & right).
Bluetooth Error	1. Change the Bluetooth Dongle. 2. Change the Card Board.
Alien Object Inside	Clean
Others	-
Noise	1. Clean. 2. Lubricate.
Printer Off-Line	1. Update printer firmware. 2. Change the Printer Main Board.
System Cooling	Change the TPH.
LCD No/Wrong Signal	1. Change the CTRL Board. 2. Change the Kiosk Main Board. 3. Change the LCD Touch Panel.

Horizontal Line (Interval between bandings lines)

For problems such as below 2 pictures, please refer to the reference chart to check which roller is causing it. Gray chart image are recommended to check the banding problem.

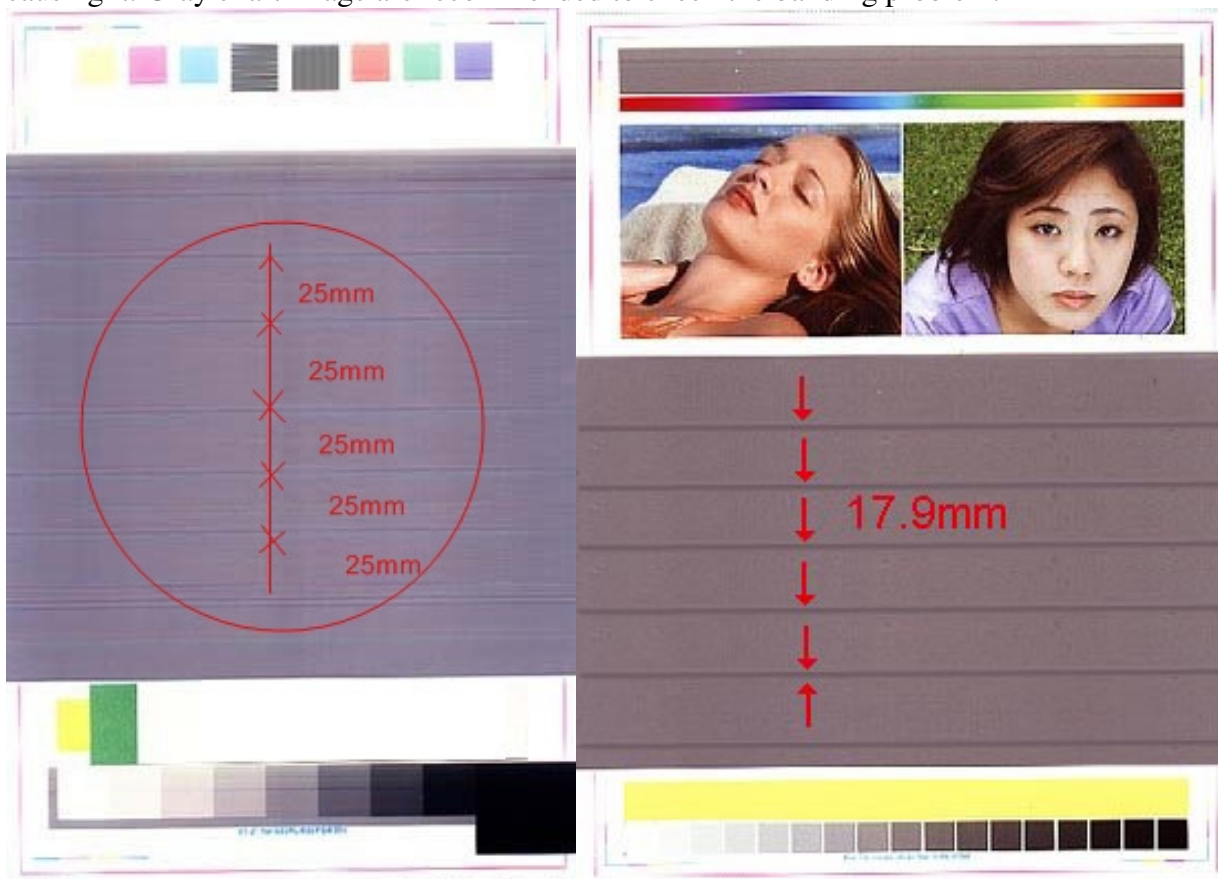

Reference Chart

Pitch Diameter	Jitter Pitch (mm)
Pulley Driver Motor	8.43
Pulley Capstan_Compound(pulley)	38.33
Pulley Capstan_Compound(gear)	38.33
Idle wheel	9.63
Capstan roller	38.33
Pinch Roller	37.7
Platen Roller	56.55
L_Gear_Driver_Idle	79.05
L_Gear_Driver	47.91
L_Gear_Swing_A5_M1	63.04
L_Gear_TQL_Driver_C	90.78
L_Gear_Roller_Feed	45.39
L_Holder_Tube_Paper	204.24

Chapter 9: Contact Information

Website: www.hiti.com

Email: service2@hiti.com

Taiwan (Asia) - Headquarters

HiTi Digital, Inc.

9F., No.225, Sec. 3, Beixin Rd., Xindian Dist., New Taipei City 231, Taiwan (R.O.C.)

TEL: +886-2-2912-6268

FAX: +886-2-2912-6117,+886-2-2912-6118

China

No.58, XinQing Road, Suzhou Industrial Park, JiangSu, China

TEL: +86-512-8228-1688 FAX: +86-512-8228-1690

United States (North America)

727 Brea Canyon Rd. Suite#2 Walnut, CA 91789, U.S.A.

TEL: +1-909-594-0099 FAX: +1-909-598-0011

Netherlands (Europe)

Esp 206, 5633 AC, Eindhoven, The Netherlands

TEL:+44-20-3286-3030 (English)

TEL:+33-977-217-595 (Français)

TEL:+31-40-256-5166 (Nederlands, Español, Português)

FAX:+31-40-290-3176

India

401/402, 4th floor, 96, Siddharth Building, Nehru Place, New Delhi 110019

TEL: +91-11-4180-8191 FAX: +91-11-4180-8193

UAE (Middle East and Africa)

Office No. 1608, Indigo Icon Tower, JLT, Dubai - U.A.E.

TEL: +971-4-3674547 FAX: +971-4-3674221

Mexico (South America)

Agustín Gonzalez de Cossio No. 1-202 Col. Del Valle,

C.P. 03100, Mexico, D. F.Mexico

TEL: +52-55-50253671, +52-55-50253672

FAX:+52-55-11076206 ext. 111